



# *Elektrim* TECHTOP

Product Catalogue

# **Elektrim** TECHTOP

PRODUCT CATALOGUE

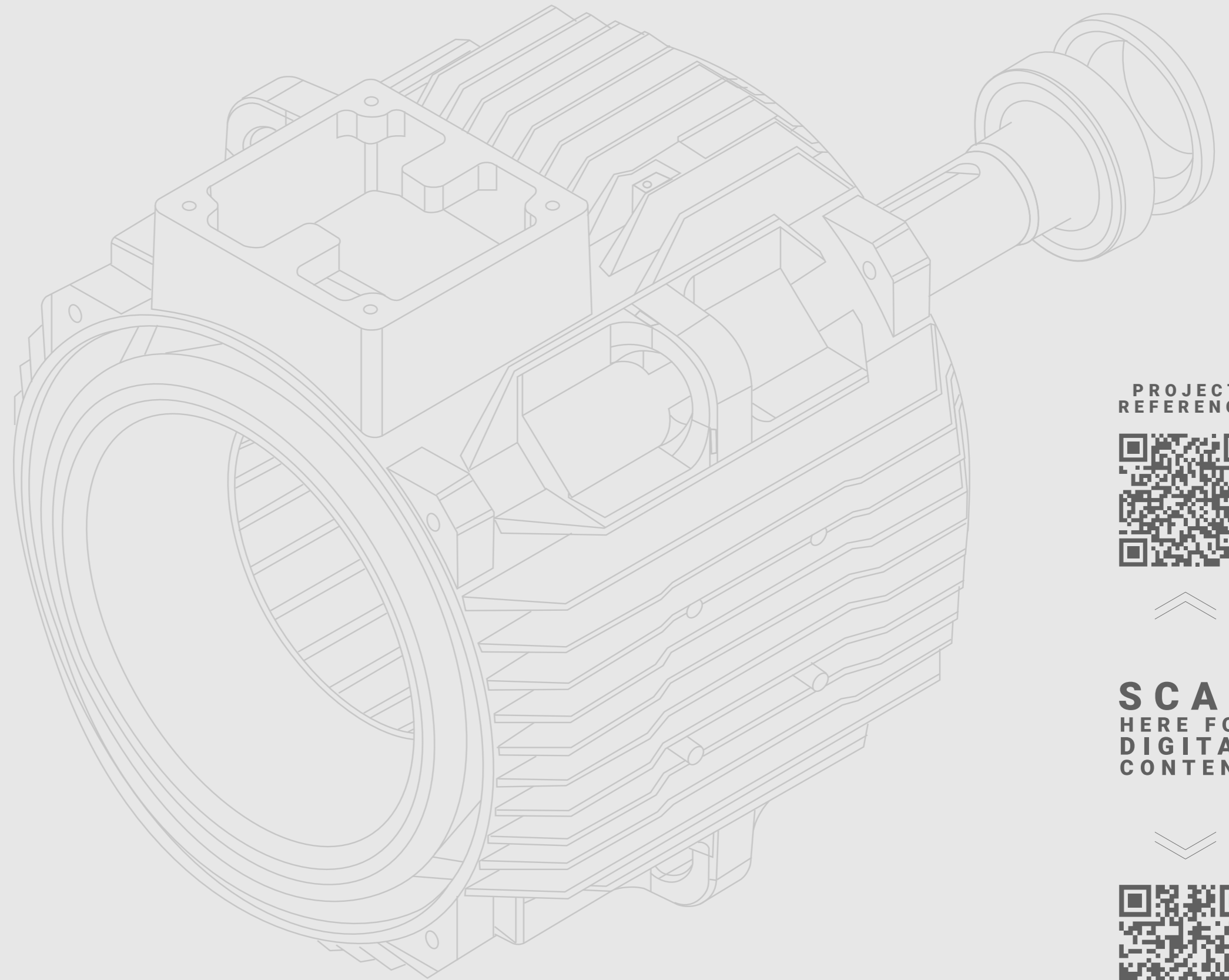

PROJECT  
REFERENCE

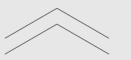

**SCAN**  
HERE FOR  
DIGITAL  
CONTENT



WEBSITE

# Elektrim TECHTOP

**Elektrim Techtop** is a collaboration between two highly experienced companies in the electric motor industry. Our aim is to provide our customers with the highest quality electric motors on a global scale. We are committed to delivering excellent customer service and satisfaction, which is our top priority. To ensure this, we have the best after-sales policy in the industry, as well as a team of professional technical personnel and experienced sales representatives.

Our partnership has enabled us to provide personalized service and flexible product distribution in over 20 countries worldwide. This means that our customers can access our services and products easily, no matter where they are located. We are committed to **Driving Our Global Brand with Localized Service**, and we look forward to providing you with the best electric motors in the industry.

Established in 1981 as Elektrim Motors & Machinery Pte Ltd, our company has emerged as a prominent powerhouse in the motor industry over the last four decades. Our motto is to be **The Driving Force Behind Every Machine**. We have built a strong regional presence across more than 10 Asian countries, with branch offices situated in the East and West of Malaysia, as well as in the North and South of Vietnam, and we have formed partnerships with agents and distributors across the rest of the region. Our customers' needs are always well attended to.

Situated in Singapore, our Regional Headquarters covers an expansive area of 50,000 square feet and maintains an inventory valued at over S\$3 million to cater to the needs of our customers. Our extensive product line includes 14 types of AC motors that adhere to both IEC or NEMA standards, suitable for various industries.

Our brand is the No. 1 specialized brand in supplying electric motors to various industries such as the Palm Oil Industry, Water & Oil Pump, Fire Pump, and Quarry Mining. Our brand is well recognized and trusted in sectors like Rubber Machinery, Industrial Fan, Marine & Offshore Engineering, Agricultural, Buildings, Cement and particularly among OEM production.

# GLOBAL MAP



## SINGAPORE REGIONAL HQ

ELEKTRIM TECHTOP  
MOTORS PTE LTD

80 Joo Koon Circle  
Singapore 629100

+65 6863 9500

enquiry@emm-motors.com

## HONG KONG HONG KONG

ZENITH INTERNATIONAL  
ENTERPRISE LTD.

## PHILIPPINES MANILA

PT CERNA CORPORATION

## SRI LANKA MOUNT LAVINIA

SM INTERNATIONAL  
PTE., LTD

## MALAYSIA KUALA LUMPUR

ELEKTRIM TECHTOP  
MOTORS SDN BHD

No. 12 to 18, Jalan Apollo U5/188,  
Seksyen U5, Bandar Pinggiran  
Subang, 40150 Shah Alam  
Selangor Darul Ehsan, Malaysia

+603 7847 6635

enquiry@emm-motors.com

## MYANMAR YANGON

MYANMA MANAW  
CO., LTD

## CAMBODIA PHNOM PENH

LPS CAMBODIA CO.

## INDONESIA SURABAYA

PT INTERJAYA  
SURYAMEGAH

MEDAN  
PT JAYATECH PALMINDO

BATAM  
PT BIOTANI INDONESIA

## AUSTRALIA VICTORIA

TECHTOP AUSTRALIA  
PTY LTD

## GERMANY HESSE

TECHTOP ADDA  
MOTOR GMBH

## ITALY BOLOGNA

SIMOTOP CROUP  
SPA

## USA GEORGIA

TECHTOP  
INDUSTRIES INC.

## VIETNAM HO CHI MINH

ELEKTRIM MOTORS &  
MACHINERY (VIETNAM)  
PTE LTD

8th Floor, Bao Minh Tower, No.217  
Nam Ky Khoi Nghia Street, Ward 7,  
District 3, Ho Chi Minh City, Vietnam

+84 8 3932 0500

info@elektrim.com.vn

## HANOI

4th Floor, Hoang Sam Building, No.260-262  
Ba Trieu Street, Le Dai Hanh Ward, Hai Ba  
Trung District, Ha Noi, Vietnam

+84 24 3200 9080

info@elektrim.com.vn

## BANGLADESH SINGAPORE OFFICE

USAFE TRADING PTE LTD

## EAST MALAYSIA PENANG

MOTRADE SDN BHD

SABAH  
MILLIVEST SDN BHD  
(EAST MALAYSIA) SDN BHD

SARAWAK  
UNIPAKAR MACHINERY  
SDN BHD

## UNITED KINGDOM UK

TEC ELECTRIC MOTORS LTD

## SPAIN BARCELONA

DIMOTOR S.A.

## CANADA ONTARIO

TECHTOP CANADA INC.

## U.A.E DUBAI

GLOBAL POWER  
ENGINEERING CO. LTD.

# CONTENT PAGE



THE

# DRIVING FORCE

BEHIND EVERY MACHINE

**01**

GENERAL  
INFORMATION

**04**

INDUCTION  
MOTORS  
**IE1** EFFICIENCY  
CAST IRON

**07**

INDUCTION  
MOTORS  
**IE2** EFFICIENCY  
CAST IRON

**09**

INDUCTION  
MOTORS  
**IE3** EFFICIENCY  
CAST IRON

**12**

INDUCTION  
MOTORS  
**IE4** EFFICIENCY  
CAST IRON

**14**

CLASS H MOTORS  
HIGH TEMPERATURE

**16**

ALUMINIUM  
MOTORS  
**IE1** EFFICIENCY

**17**

ALUMINIUM  
MOTORS  
**IE3** EFFICIENCY

**18**

DUAL SPEED  
MOTORS

**18**

TENV MOTORS

**18**

INVERTER  
MOTORS

**20**

SINGLE PHASE  
MOTORS

**22**

BRAKE MOTORS

**23**

SLIP RING  
MOTORS

**26**

NEMA MOTORS  
PREMIUM EFFICIENCY  
EPACT EFFICIENCY

**29**

HIGH VOLTAGE  
MOTORS

**30**

FIRE PUMP  
MOTORS  
UL LISTED

**31**

EXPLOSION PROOF  
MOTORS  
ATEX CERTIFICATE

**32**

MARINE MOTORS  
GL-DNV CERTIFICATE

## EU EFFICIENCY LEVEL CLASSIFICATION

An agreement has been reached between CEMEP and the European Union with the objective of reducing the power requirement of electric motors and energy consumption in Europe. This agreement affects 2, 4, 6 and 8 pole three phase AC motors, specifically standard motors that are defined as totally enclosed fan cooled, squirrel cage low voltage motors with 380V to 415V, running at 50Hz in the rated output range of 0.75kW to 90kW.

In the output range of 0.75kW to 90kW, the standard three phase motors described in this documentation correspond with the EU efficiency classification IE1 to IE5. The Efficiency designation and information of these motors is indicated on the nameplate. It is important to note that this agreement aims to contribute to energy efficiency and reduction of power consumption, and as such, adherence to these standards is recommended.

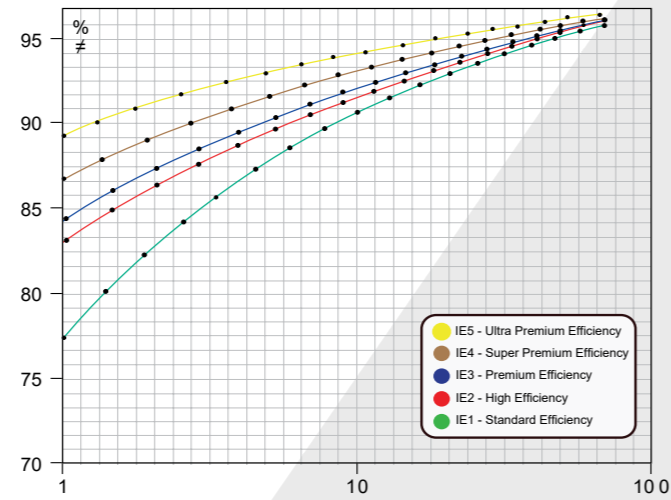

2 Pole	IE1	IE2	IE3	IE4	IE5
kW	min- π%	min- π%	min- π%	min- π%	min- π%
1.1	75	79.6	82.7	85.2	87.8
1.5	77.2	81.3	84.2	86.5	88.9
2.2	79.7	83.2	85.9	88	90.2
3	81.5	84.6	87.1	89.1	91.1
4	83.1	85.8	88.1	90	91.8
5.5	84.7	87	89.2	90.9	92.6
7.5	86	88.1	90.1	91.7	93.3
11	87.6	89.4	91.2	92.6	94
15	88.7	90.3	91.9	93.3	94.5
18.5	89.3	90.9	92.4	93.7	94.9
22	89.9	91.3	92.7	94	95.1
30	90.7	92	93.3	94.5	95.5
37	91.2	92.5	93.7	94.8	95.8
45	91.7	92.9	94	95	96
55	92.1	93.2	94.3	95.3	96.2
75	92.7	93.8	94.7	95.6	96.5
90	93	94.1	95	95.8	96.6

4 Pole	IE1	IE2	IE3	IE4	IE5
kW	min- π%	min- π%	min- π%	min- π%	min- π%
1.1	75	81.4	84.1	87.2	89.5
1.5	77.2	82.8	85.3	88.2	90.4
2.2	79.7	84.3	86.7	89.5	91.4
3	81.5	85.5	87.7	90.4	92.1
4	83.1	86.6	88.6	91.1	92.8
5.5	84.7	87.7	89.6	91.9	93.4
7.5	86	88.7	90.4	92.6	94
11	87.6	89.8	91.4	93.3	94.6
15	88.7	90.6	92.1	93.9	95.1
18.5	89.3	91.2	92.6	94.2	95.3
22	89.9	91.6	93	94.5	95.5
30	90.7	92.3	93.6	94.9	95.9
37	91.2	92.7	93.9	95.2	96.1
45	91.7	93.1	94.2	95.4	96.3
55	92.1	93.5	94.6	95.7	96.5
75	92.7	94	95	96	96.7
90	93	94.2	95.2	96.1	96.9

\*Efficiency graph and table are used for illustration purposes only, and comply with IEC requirements. Kindly contact Elektrim sales personnel for detailed efficiency data for our motors.

## DEGREES OF PROTECTION

DESIGNATION	FIRST NUMERAL	SECOND NUMERAL
	Protection against contact and ingress of foreign bodies	Protection against water
	5. Ingress of dust is not totally prevented, but dust shall not interfere with the satisfactory operation of equipment. A probe of 1mm diameter shall not penetrate the enclosure.	5. Water projected in jets against the enclosure from any direction will have no harmful effects.
	6. No ingress of dust	6. Water projected in power jets shall have no harmful effects.
<b>IP55</b>	Dust protected	Jetting water
<b>IP56</b>	Dust protected	Powerful Jetting
<b>IP65</b>	Dust tight	Jetting water
<b>IP66</b>	Dust tight	Powerful Jetting

## MOUNTING ARRANGEMENTS

FOOT MTG HORIZ	FLANGE MTG	FOOT/FLANGE MTG	FOOT MTG VERT
B3 IM1001 H80 ~ 355	B5 IM3001 H80 ~ 280	B35 IM2001 H80 ~ 355	
B6 IM1051 H80 ~ 160	V1 IM3011 H80 ~ 355	V15 IM2011 H80 ~ 160	V5 IM1011 H80 ~ 160
B7 IM1061 H80 ~ 160	V3 IM3031 H80 ~ 160	V36 IM2031 H80 ~ 160	V6 IM1031 H80 ~ 160
B8 IM1071 H80 ~ 160			

## BEARING DATA

Frame	Drive End Bearing	Non-drive End Bearing	Quantity of Grease in Bearing Chamber (grams)
EM 63	6201C3	6201C3	Life Bearing
EM 70	6202C3	6202C3	Life Bearing
EM 80	6204C3	6204C3	Life Bearing
EM 90	6205C3	6205C3	Life Bearing
EM 100	6206C3	6206C3	Life Bearing
EM 112	6306C3	6306C3	Life Bearing
EM 132	6308C3	6308C3	Life Bearing
EM 160	6309C3	6309C3	12
EM 180	6311C3	6311C3	15
EM 200	6312C3	6312C3	20
EM 225	6313C3	6313C3	22
FM 250	6314C3	6314C3	23
EM 280 (2P)	6316C3	6316C3	30
EM 280 (4P - 8P)	6316C3	6316C3	30
EM 315 (2P)	6317C3	6317C3	30
EM 315 (4P - 8P)	NU319	6319 C3	45
EM 355 (2P)	6319 C3	6319 C3	30
EM 355 (4P - 8P)	NU322	6322 C3	60

## TEMPERATURE

	INSULATION CLASS	
	Class F	Class H
Max. permissible winding temperature (°C)	155	180
Max. ambient temperature (°C)	45	80
Min. ambient temperature (°C)	-15	-15
Max. hours of operation at max. temperature	Unlimited	2 Hours
Max. permissible humidity (%)	100	100
Temperature rise safety margin (K)	80K	125K

\* The motor types listed in this catalogue are only for base models. For more information on motor modifications beyond the standard model and mounting options, kindly contact your Elektrim sales personnel for more information.

## DIMENSIONAL DRAWING

CAST IRON - IE1 & IE2

\*all dimensions are measured in mm

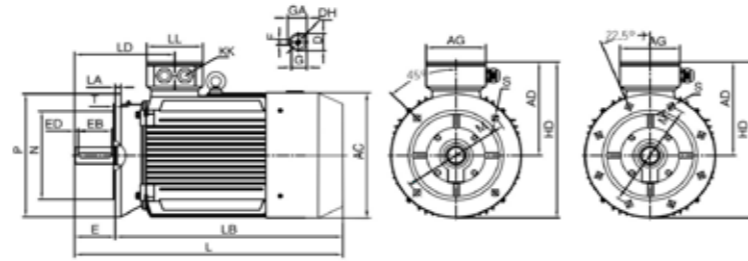

FLANGE MOUNTED B5

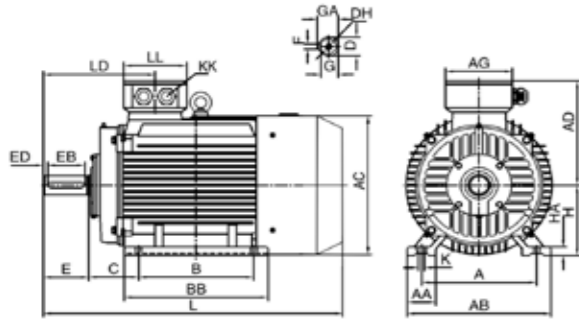

FOOT MOUNTED B3

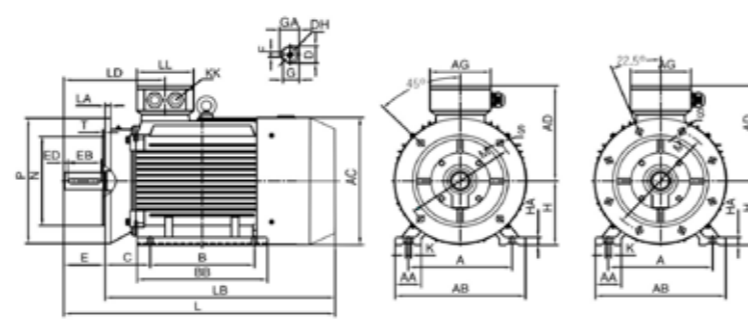

FOOT & FLANGE MOUNTED B35

Frame Size	A	AA	AB	AC	AD	AG	B	BB	C	D	DH	E	EB	ED	F	G	GA	H	HA	K	KK	L	LA	LB	LD	LL	N	P	S	T	
80	2,4,6,8	125	34	160	155.4	131	94	100	130	50	19	M6X16	40	30	5	6	15.5	21.5	80	10	4-Φ10	M20*1.5	284	12	244	112	94	130	200	12	3.5
90S	2,4,6,8	140	36	176	175.4	148	102	100	130	56	24	M8X19	50	40	5	8	20	27	90	12	4-Φ10	M20*1.5	318	12	258	130	102	130	200	12	3.5
90L	2,4,6,8	140	36	176	175.4	148	102	125	155	56	24	M8X19	50	40	5	8	20	27	90	12	4-Φ10	M20*1.5	343	12	283	130	102	130	200	12	3.5
100L	2,4,6,8	160	40	200	195.4	162	102	140	176	63	28	M10X22	60	50	5	8	24	31	100	14	4-Φ12	M20*1.5	370	13	320	139	102	180	250	14.5	4
112M	2,4,6,8	190	45	226	219.4	183	118	140	180	70	28	M10X22	60	50	5	8	24	31	112	15	4-Φ12	M25*1.5	394	14	334	147	110	180	250	14.5	4
132S	2,4,6,8	216	55	262	258.4	203	118	140	186	89	38	M12X28	80	65	7.5	10	33	41	132	18	4-Φ12	M25*1.5	456	14	390	172	110	230	300	14.5	4
132M	4,6,8	216	55	262	258.4	203	118	178	224	89	38	M12X28	80	65	7.5	10	33	41	132	18	4-Φ12	M25*1.5	494	14	428	172	110	230	300	14.5	4
160M	2,4,6,8	254	65	314	314	251	162	210	260	108	42	M16X36	110	90	10	12	37	45	160	20	4-Φ14.5	M32*1.5	608	15	498	256	152	250	350	18.5	5
160L	2,4,6,8	254	65	314	314	251	162	254	304	108	42	M16X36	110	90	10	12	37	45	160	20	4-Φ14.5	M32*1.5	652	15	542	256	152	250	350	18.5	5
180M	2,4,8	279	70	349	355	267	162	241	311	121	48	M16X36	110	90	10	14	42.5	51.5	180	22	4-Φ14.5	M32*1.5	688	15	578	271	152	250	350	18.5	5
180L	4,6,8	279	70	349	355	267	162	279	349	121	48	M16X36	110	90	10	14	42.5	51.5	180	22	4-Φ14.5	M32*1.5	726	15	616	271	152	250	350	18.5	5
200L	2,4,6,8	318	70	388	397	299	210	305	369	133	55	M20X42	110	100	5	16	49	59	200	25	4-Φ18.5	M32*1.5	771	17	661	296	190	300	400	18.5	5
225S	4,8	356	75	431	446	322	210	286	368	149	60	M20X42	140	125	7.5	18	53	64	225	28	4-Φ18.5	M50*1.5	824	20	684	329	190	350	450	18.5	5
225M	2	356	75	431	446	322	210	311	393	149	55	M20X42	110	100	5	16	49	59	225	28	4-Φ18.5	M50*1.5	819	20	709	299	190	350	450	18.5	5
225M	4,6,8	356	75	431	446	322	210	311	393	149	60	M20X42	140	125	7.5	18	53	64	225	28	4-Φ18.5	M50*1.5	849	20	709	329	190	350	450	18.5	5
250M	2	406	80	484	485	358	248	349	445	168	60	M20X42	140	125	7.5	18	53	64	250	30	4-Φ24	M50*1.5	910	22	770	347	218	450	550	18.5	5
250M	4,6,8	406	80	484	485	358	248	349	445	168	65	M20X42	140	125	7.5	18	58	69	250	30	4-Φ24	M50*1.5	910	22	770	347	218	450	550	18.5	5
280S	2	457	85	542	547	387	248	368	485	190	65	M20X42	140	125	7.5	18	58	69	280	35	4-Φ24	M50*1.5	982	22	842	355.5	218	450	550	18.5	5
280S	4,6,8	457	85	542	547	387	248	368	485	190	75	M20X42	140	125	7.5	20	67.5	79.5	280	35	4-Φ24	M50*1.5	982	22	842	355.5	218	450	550	18.5	5
280M	2	457	85	542	547	387	248	419	536	190	65	M20X42	140	125	7.5	18	58	69	280	35	4-Φ24	M50*1.5	1033	22	893	355.5	218	450	550	18.5	5
280M	4,6,8	457	85	542	547	387	248	419	536	190	75	M20X42	140	125	7.5	20	67.5	79.5	280	35	4-Φ24	M50*1.5	1033	22	893	355.5	218	450	550	18.5	5
315S	2	508	120	628	620	527	320	406	570	216	65	M20X42	140	125	7.5	18	58	69	315	45	4-Φ28	M63*1.5	1178	22	1038	397	280	550	660	24	6
315S	4,6,8,10	508	120	628	620	527	320	406	570	216	80	M20X42	170	160	5	22	71	85	315	45	4-Φ28	M63*1.5	1208	22	1038	427	280	550	660	24	6
315M	2	508	120	628	620	527	320	457	680	216	65	M20X42	140	125	7.5	18	58	69	315	45	4-Φ28	M63*1.5	1288	22	1148	397	280	550	660	24	6
315M	4,6,8,10	508	120	628	620	527	320	457	680	216	80	M20X42	170	160	5	22	71	85	315	45	4-Φ28	M63*1.5	1318	22	1148	427	280	550	660	24	6
315L	2	508	120	628	620	527	320	508	680	216	65	M20X42	140	125	7.5	18	58	69	315	45	4-Φ28	M63*1.5	1288	22	1148	397	280	550	660	24	6
315L	4,6,8,10	508	120	628	620	527	320	508	680	216	80	M20X42	170	160	5	22	71	85	315	45	4-Φ28	M63*1.5	1318	22	1148	427	280	550	660	24	6
355M	2	610	116	726	698	642	380	560	750	254	75	M20X42	140	130	5	20	67.5	79.5	355	52	6-Φ28	M63*1.5	1486	25	1346	414	330	680	800	24	6
355M	4,6,8,10	610	116	726	698	642	380	560	750	254	95	M24X50	170	160	5	25	86	100	355	52	6-Φ28	M63*1.5	1516	25	1346	444	330	680	800	24	6
355L	2	610	116	726	698	642	380	630	750	254	75	M20X42	140	130	5	20	67.5	79.5	355	52	6-Φ28	M63*1.5	1486	25	1346	414	330	680	800	24	6
355L	4,6,8,10	610	116	726	698	642	380	630	750	254	95	M24X50	170	160	5	25	86	100	355	52	6-Φ28	M63*1.5	1516	25	1346	444	330	680	800	24	6

# INDUCTION MOTORS

THREE-PHASE ASYNCHRONOUS MOTORS  
CAST IRON HOUSING

The EMM series of three-phase asynchronous motors are constructed as Totally Enclosed Fan Cooled (TEFC) and are available in both cast iron and aluminum housing. They encompass our latest design with many new features, are made of selected high-quality materials, and conform to the IEC Standard.

Some unique design features include our special conical pro-ventilation fan cover, detachable feet for cast iron housing, and an extended aluminum housing range up to frame size 200. EMM series motors come with Protection IP55, Insulation Class F, and SKF imported bearings as standard. These series of motors can be used for general drives.

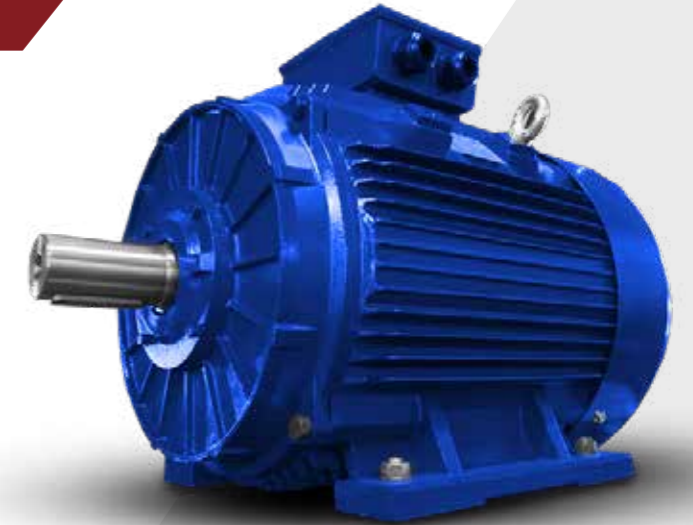

## TECHNICAL DATA

CAST IRON - IE1 2POLE

Motor Type	Rated Output		Rated Speed rpm	IFL 380V (AMP)	IFL 400V (AMP)	IFL 415V (AMP)	EFF %	Power Factor	Rated Torque Nm	Locked Rotor Torque TST/ TFL	Maximum Torque TM/ TFL	Locked Rotor Current IST/ IFL	M of J kgm2	Noise Level LW dB(A)	Net Weight kg
	kW	HP													
EM80A-2	0.75	1	2830	1.90	1.81	1.74	72.1	0.83	2.5	2.2	2.3	6.1	0.001	62	16
EM80B-2	1.1	1.5	2830	2.65	2.52	2.43	75	0.84	3.7	2.2	2.3	6.9	0.002	62	17
EM90S-2	1.5	2	2840	3.51	3.34	3.22	77.2	0.84	5	2.2	2.3	7	0.002	67	20
EM90L-2	2.2	3	2840	4.93	4.69	4.52	79.7	0.85	7.4	2.2	2.3	7	0.003	67	23
EM100L-2	3	4	2870	6.43	6.11	5.89	81.5	0.87	10	2.2	2.3	7.5	0.005	74	29
EM112M-2	4	5.5	2890	8.31	7.90	7.61	83.1	0.88	13.3	2.2	2.3	7.5	0.008	77	41
EM132SA-2	5.5	7.5	2900	11.2	10.7	10.3	84.7	0.88	18.1	2.2	2.3	7.5	0.014	79	57
EM132SB-2	7.5	10	2900	15.1	14.3	13.8	86	0.88	24.5	2.2	2.3	7.5	0.018	79	60
EM160MA-2	11	15	2930	21.4	20.4	19.6	87.6	0.89	35.8	2.2	2.3	7.5	0.051	81	104
EM160MB-2	15	20	2930	28.9	27.4	26.4	88.7	0.89	48.8	2.2	2.3	7.5	0.064	81	106
EM160L-2	18.5	25	2930	35.0	33.2	32.0	89.3	0.9	60.4	2.2	2.3	7.5	0.076	81	132
EM180M-2	22	30	2940	41.3	39.2	37.8	89.9	0.9	71.4	2	2.3	7.5	0.105	83	155
EM200LA-2	30	40	2950	55.8	53.0	51.1	90.7	0.9	97.2	2	2.3	7.5	0.179	84	217
EM200LB-2	37	50	2950	68.5	65.1	62.7	91.2	0.9	119.8	2	2.3	7.5	0.201	84	228
EM225M-2	45	60	2970	82.8	78.7	75.9	91.7	0.9	144.8	2	2.3	7.5	0.305	86	286
EM250M-2	55	75	2970	101	95.8	92.3	92.1	0.9	177	2	2.3	7.5	0.414	89	354
EM280S-2	75	100	2970	137	130	125	92.7	0.9	241.3	2	2.3	7	0.695	91	493
EM280M-2	90	125	2970	162	154	148	93	0.91	289.5	2	2.3	7.1	0.852	91	505
EM315S-2	110	150	2980	197	187	180	93.3	0.91	352.7	1.8	2.2	7.1	1.753	92	870
EM315M-2	132	180	2980	236	224	216	93.5	0.91	423.2	1.8	2.2				

CAST IRON - IE1 4 POLE

Motor Type	Rated Output		Rated Speed rpm	IFL 380V (AMP)	IFL 400V (AMP)	IFL 415V (AMP)	EFF %	Power Factor	Rated Torque Nm	Locked Rotor Torque TST/ TFL	Maximum Torque TM/ TFL	Locked Rotor Current IST/ IFL	M of J kgm2	Noise Level LW dB(A)	Net Weight kg
	kW	HP													
EM80A-4	0.55	0.75	1390	1.59	1.51	1.46	70	0.75	3.8	2.4	2.3	5.2	0.001	56	15
EM80B-4	0.75	1	1390	2.08	1.98	1.90	72.1	0.76	5.2	2.3	2.3	6	0.003	56	16
EM90S-4	1.1	1.5	1400	2.89	2.75	2.65	75	0.77	7.5	2.3	2.3	6	0.004	59	19
EM90L-4	1.5	2	1400	3.78	3.60	3.47	77.2	0.78	10.2	2.3	2.3	6	0.006	59	23
EM100LA-4	2.2	3	1430	5.18	4.92	4.74	79.7	0.81	14.8	2.3	2.3	7	0.01	64	29
EM100LB-4	3	4	1430	6.82	6.48	6.25	81.5	0.82	20.2	2.3	2.3	7	0.013	64	31
EM112M-4	4	5.5	1440	8.92	8.47	8.17	83.1	0.82	26.5	2.3	2.3	7	0.019	65	41
EM132S-4	5.5	7.5	1440	11.9	11.3	10.9	84.7	0.83	36.5	2.3	2.3	7	0.036	71	52
EM132M-4	7.5	10	1440	15.8	15.0	14.4	86	0.84	49.8	2.3	2.3	7	0.047	71	64
EM160M-4	11	15	1460	22.7	21.6	20.8	87.6	0.84	72	2.2	2.3	7	0.103	73	100
EM160L-4	15	20	1460	30.2	28.7	27.7	88.7	0.85	98.2	2.2	2.3	7.5	0.131	73	127
EM180M-4	18.5	25	1470	36.6	34.8	33.5	89.3	0.86	120.2	2.2	2.3	7.5	0.183	76	150
EM180L-4	22	30	1470	43.2	41.1	39.6	89.9	0.86	143	2.2	2.3	7.5	0.219	76	165
EM200L-4	30	40	1470	58.4	55.5	53.5	90.7	0.86	195	2.2	2.3	7.2	0.297	76	226
EM225S-4	37	50	1480	70.9	67.3	64.9	91.2	0.87	238.9	2.2	2.3	7.2	0.578	78	265
EM225M-4	45	60	1480	85.7	81.4	78.5	91.7	0.87	290.5	2.2	2.3	7.2	0.659	78	311
EM250M-4	55	75	1480	104	99.1	95.5	92.1	0.87	355.1	2.2	2.3	7.2	0.818	79	365
EM280S-4	75	100	1480	140	133	128	92.7	0.88	483.9	2.2	2.3	6.8	1.571	80	480
EM280M-4	90	125	1480	167	159	153	93	0.88	580.7	2.2	2.3	6.8	1.964	80	555
EM315S-4	110	150	1480	204	193	186	93.3	0.88	709.8	2.1	2.2	6.9	3.247	88	845
EM315M-4	132	180	1490	244	232	223	93.5	0.88	851.8	2.1	2.2	6.9	3.527	88	930
EM315LA-4	160	220	1490	291	277	267	93.8	0.89	1032	2.1	2.2	6.9	4.087	88	1030
EM315L-4	185	250	1485	322	313	304	94	0.9	1189.7	2.1	2.2	6.9	4.927	88	1090
EM315LB-4	200	270	1490	359	345	329	94	0.9	1290	2.1	2.2	6.9	5.374	88	1150
EM355MA-4	220	300	1485	395	375	362	94	0.9	1411	2.1	2.2	6.9	7.6	95	1600
EM355MB-4	250	340	1485	449	427	411	94	0.9	1603	2.1	2.2	6.9	8.4	95	1680
EM355LA-4	280	375	1485	503	478	460	94	0.9	1796	2.1	2.2	7.1	9.2	95	1790
EM355L-4	315	430	1485	566	537	518	94	0.9	2020	2.1	2.2	7.1	9.9	95	1900
EM355LB-4	355	475	1490	638	605	584	94	0.9	2275.3	2	2.2	6.9	11.2	95	2000

CAST IRON - IE1 8 POLE

Motor Type	Rated Output		Rated Speed rpm	IFL 380V (AMP)	IFL 400V (AMP)	IFL 415V (AMP)	EFF %	Power Factor	Rated Torque Nm	Locked Rotor Torque TST/ TFL	Maximum Torque TM/ TFL	Locked Rotor Current IST/ IFL	M of J kgm2	Noise Level LW dB(A)	Net Weight kg
	kW	HP													
EM80A-8	0.18	0.25	710	1.18	1.12	1.08	38	0.61	2.8	1.8	1.9	3.3	0.002	52	13
EM80B-8	0.25	0.37	710	1.43	1.36	1.31	43.4	0.61	3.7	1.8	1.9	3.3	0.003	52	15
EM90S-8	0.37	0.5	720	1.85	1.76	1.70	49.7	0.61	5.4	1.8	1.9	4	0.003	56	19
EM90L-8	0.55	0.75	720	2.44	2.32	2.24	56.1	0.61	8	1.8	2	4	0.005	56	20
EM100LA-8	0.75	1	720	2.78	2.64	2.54	61.2	0.67	10.4	1.8	2	4	0.008	59	29
EM100LB-8	1.1	1.5	730	3.64	3.46	3.34	66.5	0.69	15.2	1.8	2	5	0.010	59	31
EM112M-8	1.5	2	730	4.64	4.41	4.25	70.2	0.7	20.8	1.8	2	5	0.017	61	39
EM132S-8	2.2	3	730	6.34	6.03	5.81	74.2	0.71	29.6	1.8	2	6	0.031	64	61
EM132M-8	3	4	730	8.11	7.70	7.43	77	0.73	40.4	1.8	2	6	0.040	64	75
EM160MA-8	4	5.5	740	10.5	9.99	9.63	79.2	0.73	53.1	1.9	2	6	0.075	68	90
EM160MB-8	5.5	7.5	740	13.9	13.2	12.7	81.4	0.74	73	1.9	2	6	0.093	68	103
EM160L-8	7.5	10	740	18.3	17.4	16.7	83.1	0.75	99.5	1.9	2	6	0.126	68	120
EM180L-8	11	15	740	26.2	24.9	24.0	85	0.75	144	2	2	6.5	0.203	70	163
EM200L-8	15	20	740	34.8	33.0	31.9	86.2	0.76	196.3	2	2	6.6	0.339	73	225
EM225S-8	18.5	25	740	42.6	40.4	39.0	86.9	0.76	242.1	1.9	2	6.6	0.491	73	255
EM225M-8	22	30	740	49.0	46.6	44.9	87.4	0.78	284	1.9	2	6.6	0.547	73	275
EM250M-8	30	40	740	65.3	62.1	59.8	88.3	0.79	387.3	1.9	2	6.5	0.830	75	350
EM280S-8	37	50	740	80.1	76.1	73.4	88.8	0.79	477.7	1.9	2	6.6	1.390	76	470
EM280M-8	45	60	740	97.0	92.2	88.8	89.2	0.79	581	1.9	2	6.6	1.650	76	520
EM315S-8	55	75	740	115	109	105	89.7	0.81	710.1	1.8	2	6.6	4.790	82	810
EM315M-8	75	100	740	156	148	143	90.3	0.81	968.3	1.8	2	6.2	5.580	82	900
EM315LA-8	90	125	740	184	175	168	90.7	0.82	1162	1.8	2	6.4	6.370	82	980
EM315LB-8	110	150	740	224	213	205	91.1	0.82	1420	1.8	2	6.4	7.230	82	995
EM355M-8	132	180	740	267	254	245	91.5	0.82	1704	1.8	2	6.4	7.600	90	1700
EM355MA-8	160	220	740	323	306	295	91.9	0.82	2066	1.8	2	6.4	11.700	90	1850
EM355MB-8	185	250	740	367	348	336	92.5	0.82	2388	1.8	2	6.3	12.500	89	1900
EM355L-8	200	270	740	396	376	362	92.5	0.83	2582	1.8	2	6.4	12.900	90	1930
EM355LA-8	220	300	740	435	414	399	92.5	0.83	2839	1.8	2	6.4	13.900	89	2000
EM355LB-8	250	340	740	495	471	453	92.5	0.83	3226	1.8	2	6.4	14.200	89	2120

CAST IRON - IE1 6 POLE

Motor Type	Rated Output		Rated Speed rpm	IFL 380V (AMP)	IFL 400V (AMP)	IFL 415V (AMP)	EFF %	Power Factor	Rated Torque Nm	Locked Rotor Torque TST/ TFL	Maximum Torque TM/ TFL	Locked Rotor Current IST/ IFL	M of J kgm2	Noise Level LW dB(A)	Net Weight kg
	kW	HP													
EM80A-6	0.37	0.5	900	1.35	1.28	1.23	59.7	0.7	4	1.9	2	4.7	0.002	54	15
EM80B-6	0.55	0.75	900	1.76	1.68	1.62	65.8	0.72	5.9	1.9	2.1	4.7	0.003	54	16
EM90S-6	0.75	1	910	2.26	2.15	2.07	70	0.72	7.9	2	2.1	4.7	0.005	57	20
EM90L-6	1.1	1.5	910	3.14	2.98	2.88	72.9	0.73	11.5	2	2.1	5.3	0.008	57	23
EM100L-6	1.5	2	940	4.04	3.84	3.70	75.2	0.75	15.6	2	2.1	5.5	0.013	61	29
EM112M-6	2.2	3	940	5.66	5.38	5.18	77.7	0.76	22.4	2	2.1	5.5	0.02	65	40
EM132S-6	3	4	960	7.53	7.15	6.89	79.7	0.76	29.9	2.1	2.1	6.5	0.038	69	58
EM132MA-6	4	5.5	960	9.82	9.33	9.00	81.4	0.76	39.8	2.1	2.1	6.5	0.05	69	63
EM132MB-6	5.5	7.5	960	13.1	12.4	12.0	83.1	0.77	54.7	2.1	2.1	6.5	0.066	69	73
EM160M-6	7.5	10	970	17.2	16.6	15.8	84.7	0.78	73.9	2	2.1	6.5	0.121	73	105
EM160L-6	11	15	970	24.8	23.6	22.7	86.4	0.78	108.3	2	2.1	6.5	0.161	73	120
EM180L-6	15	20	970	32.1	30.5	29.4	87.7	0.81	147.7	2	2.1	7	0.264	73	152
EM200LA-6	18.5	25	970	39.2	37.2	35.9	88.6	0.81	182.2	2.1	2.1	7	0.407	73	200
EM200LB-6	22	30	970	45.1	42.9	41.3	89.2	0.83	216.7	2	2.1	7	0.459	73	213
EM225M-6	30	40	980	60.2	57.2	55.1	90.2	0.84	292.5	2	2.1	7	0.648	74	282
EM250M-6	37	50	980	72.0	68.4	65.9	90.8	0.86	360.7	2.1	2.1	7	0.979	76	350
EM280S-6	45	60	980	87.0	82.6	79.6	91.4	0.86	438.7	2.1	2	7	1.79	78	441
EM280M-6	55	75	980	106	100	96.8	91.9	0.86	536.2	2.1	2	7	2.164	78	493
EM315S-6	75	100	990	143	136	131	92.6	0.86	723.8	2	2	6.7	4.279	83	850
EM315M-6	90	125	990	171	163	157	92.9	0.86	868.6	2	2	6.7	5.017	83	930
EM315LA-6	110	150	990	208	198	191	93.3	0.86	1061.6	2	2	6.7	5.607	83	997
EM315LB-6	132	180	990	247	234	226	93.5	0.87	1274	2	2	6.7	6.64	83	1080
EM355MA-6	160	220	990	295	280	270	93.8	0.88	1544	1.9	2	6.7	9.6	85	1480
EM355M-6	185	250	990												

**CAST IRON - IE2 2 POLE**

Motor Type	Rated Output		Rated Speed rpm	IFL 380V (AMP)	IFL 400V (AMP)	IFL 415V (AMP)	EFF %	Power Factor	Rated Torque Nm	Locked Rotor Torque TST/ TFL	Maximum Torque TM/ TFL	Locked Rotor Current IST/ IFL	M of J kgm2	Noise Level LW dB(A)	Net Weight kg
	kW	HP													
EM2-80A-2	0.75	1	2860	1.77	1.69	1.62	77.4	0.83	2.5	2.3	2.3	6.8	0.0012	62	16
EM2-80B-2	1.1	1.5	2860	2.50	2.37	2.29	79.6	0.84	3.7	2.3	2.3	7.3	0.0017	62	17
EM2-90S-2	1.5	2	2850	3.34	3.17	3.06	81.3	0.84	5.0	2.3	2.3	7.6	0.0026	67	20
EM2-90L-2	2.2	3	2855	4.73	4.49	4.33	83.2	0.85	7.4	2.3	2.3	7.8	0.0034	67	23
EM2-100L-2	3	4	2890	6.19	5.88	5.67	84.6	0.87	9.9	2.3	2.3	8.1	0.006	74	29
EM2-112M-2	4	5.5	2895	8.05	7.65	7.37	85.8	0.88	13.2	2.3	2.3	8.3	0.0086	77	41
EM2-132SA-2	5.5	7.5	2910	11.2	10.61	10.2	87	0.86	18.0	2.2	2.3	8	0.016	79	57
EM2-132SB-2	7.5	10	2910	14.7	13.96	13.5	88.1	0.88	24.6	2.2	2.3	7.8	0.0188	79	60
EM2-160MA-2	11	15	2940	21.0	19.96	19.2	89.4	0.89	35.7	2.2	2.3	7.9	0.0618	81	104
EM2-160MB-2	15	20	2940	28.4	26.94	26.0	90.3	0.89	48.7	2.2	2.3	8	0.0674	81	106
EM2-160L-2	18.5	25	2935	34.7	33.01	31.8	90.9	0.89	60.2	2.2	2.3	8.1	0.0808	81	132
EM2-180M-2	22	30	2945	41.6	39.52	38.1	91.3	0.88	71.3	2.2	2.3	8.2	0.1003	83	155
EM2-200LA-2	30	40	2960	56.3	53.49	51.6	92	0.88	96.8	2.2	2.3	7.5	0.189	84	217
EM2-200LB-2	37	50	2960	68.3	64.87	62.5	92.5	0.89	119.4	2.2	2.3	7.5	0.1971	84	228
EM2-225M-2	45	60	2970	82.8	78.56	75.8	92.9	0.89	144.7	2.2	2.3	7.6	0.3619	86	286
EM2-250M-2	55	75	2975	100	94.64	91.2	93.2	0.9	176.6	2.2	2.3	7.6	0.4387	89	354
EM2-280S-2	75	100	2980	135	128.24	124	93.8	0.9	240.4	2	2.3	6.9	0.8084	91	493
EM2-280M-2	90	125	2980	160	151.71	146	94.1	0.91	288.4	2	2.3	7	0.9208	91	505
EM2-315S-2	110	150	2980	195	185.03	178	94.3	0.91	352.5	2	2.2	7.1	1.693	92	870
EM2-315M-2	132	180	2980	233	221.33	213	94.6	0.91	423.0	2	2.2	7.1	1.8746	92	945
EM2-315LA-2	160	220	2980	279	264.80	255	94.8	0.92	512.8	2	2.2	7.1	2.2144	92	995
EM2-315LB-2	200	270	2975	348	330.30	318	95	0.92	642.0	2	2.2	7.1	2.5171	92	1120
EM2-355MB-2	250	340	2980	435	412.88	398	95	0.92	801.2	2	2.2	7.1	3.8265	100	1890
EM2-355L-2	315	430	2980	548	520.23	501	95	0.92	1009.5	2	2.2	7.1	4.5516	100	2235

**CAST IRON - IE2 4 POLE**

Motor Type	Rated Output		Rated Speed rpm	IFL 380V (AMP)	IFL 400V (AMP)	IFL 415V (AMP)	EFF %	Power Factor	Rated Torque Nm	Locked Rotor Torque TST/ TFL	Maximum Torque TM/ TFL	Locked Rotor Current IST/ IFL	M of J kgm2	Noise Level LW dB(A)	Net Weight kg
	kW	HP													
EM2-80B-4	0.75	1	1425	1.88	1.79	1.72	79.6	0.76	5.0	2.3	2.3	6.5	0.0036	56	16.9
EM2-90S-4	1.1	1.5	1420	2.67	2.53	2.44	81.4	0.77	7.4	2.3	2.3	6.6	0.0044	59	20
EM2-90L-4	1.5	2	1425	3.57	3.40	3.27	82.8	0.77	10.1	2.3	2.3	6.9	0.0056	59	24
EM2-100LA-4	2.2	3	1440	4.90	4.65	4.48	84.3	0.81	14.6	2.3	2.3	7.5	0.0109	64	31
EM2-100LB-4	3	4	1445	6.50	6.18	5.95	85.5	0.82	19.8	2.3	2.3	7.6	0.0144	64	33
EM2-112M-4	4	5.5	1440	8.56	8.13	7.84	86.6	0.82	26.5	2.3	2.3	7.7	0.0171	65	43
EM2-132S-4	5.5	7.5	1450	11.5	10.91	10.5	87.7	0.83	36.2	2	2.3	7.5	0.0385	71	55
EM2-132M-4	7.5	10	1455	15.3	14.53	14.0	88.7	0.84	49.2	2.2	2.3	7.4	0.0514	71	68
EM2-160M-4	11	15	1465	22.2	21.05	20.3	89.8	0.84	71.7	2.2	2.3	7.5	0.1076	73	106
EM2-160L-4	15	20	1465	29.6	28.11	27.1	90.6	0.85	97.8	2.2	2.3	7.5	0.139	73	134
EM2-180M-4	18.5	25	1470	35.8	34.05	32.8	91.2	0.86	120.2	2.2	2.3	7.7	0.1913	76	158
EM2-180L-4	22	30	1475	42.4	40.31	38.9	91.6	0.86	142.4	2.2	2.3	7.8	0.2192	76	174
EM2-200L-4	30	40	1475	57.4	54.55	52.6	92.3	0.86	194.2	2.2	2.3	7.2	0.3187	76	239
EM2-225S-4	37	50	1480	69.7	66.22	63.8	92.7	0.87	238.8	2.2	2.3	7.3	0.6463	78	280
EM2-225M-4	45	60	1485	84.4	80.19	77.3	93.1	0.87	289.4	2.2	2.3	7.4	0.7547	78	328
EM2-250M-4	55	75	1480	103	97.59	94.1	93.5	0.87	354.9	2.2	2.3	7.4	0.9344	79	385
EM2-280S-4	75	100	1485	139	132.38	128	94	0.87	482.3	2.2	2.3	6.7	1.7867	80	500
EM2-280M-4	90	125	1490	167	158.51	153	94.2	0.87	576.8	2.2	2.3	6.9	2.1229	80	577
EM2-315S-4	110	150	1490	201	190.93	184	94.5	0.88	705.0	2.2	2.2	6.9	3.8188	88	867
EM2-315M-4	132	180	1485	241	228.63	220	94.7	0.88	848.9	2.2	2.2	6.9	3.8306	88	953
EM2-315LA-4	160	220	1485	288	273.44	264	94.9	0.89	1029.0	2.2	2.2	6.9	4.6727	88	1055
EM2-315LB-4	200	270	1485	359	341.08	329	95.1	0.89	1286.2	2.2	2.2	6.9	5.3463	88	1179
EM2-355MB-4	250	340	1490	444	421.61	406	95.1	0.9	1602.3	2.2	2.2	6.9	8.2188	95	1715
EM2-355L-4	315	430	1490	559	531.23	512	95.1	0.9	2019.0	2.2	2.2	6.9	10.5146	95	1940

**CAST IRON - IE2 6 POLE**

Motor Type	Rated Output		Rated Speed rpm	IFL 380V (AMP)	IFL 400V (AMP)	IFL 415V (AMP)	EFF %	Power Factor	Rated Torque Nm	Locked Rotor Torque TST/ TFL	Maximum Torque TM/ TFL	Locked Rotor Current IST/ IFL	M of J kgm2	Noise Level LW dB(A)	Net Weight kg
	kW	HP													
EM2-90S-6	0.75	1	935	2.09	1.98	1.91	75.9	0.72	7.7	2.1	2.1	5.8	0.0057	57	21
EM2-90L-6	1.1	1.5	940	2.97	2.82	2.72	78.1	0.72	11.2	2.1	2.1	5.9	0.0072	57	24
EM2-100L-6	1.5	2	950	3.81	3.62	3.49	79.8	0.75	15.1	2.1	2.1	6.0	0.0144	61	31
EM2-112M-6	2.2	3	950	5.38	5.11	4.92	81.8	0.76	22.1	2	2.1	6.0	0.0229	65	42
EM2-132S-6	3	4	960	7.20	6.84	6.59	83.3	0.76	29.8	2	2.1	6.2	0.039	69	61
EM2-132MA-6	4	5.5	960	9.45	8.98	8.66	84.6	0.76	39.8	2	2.1	6.8	0.0499	69	67
EM2-132MB-6	5.5	7.5	965	12.6	11.99	11.6	86	0.77	54.4	2	2.1	7.1	0.0714	69	77
EM2-160M-6	7.5	10	970	16.8	15.92	15.3	87.2	0.78	73.8	2.1	2.1	6.7	0.1248	73	111
EM2-160L-6	11	15	970	24.2	22.95	22.1	88.7	0.78	108.3	2.1	2.1	6.9	0.18	73	127
EM2-180L-6	15	20	975	31.4	29.80	28.7	89.7	0.81	146.9	2	2.1	7.2	0.3415	73	160
EM2-200LA-6	18.5	25	980	38.4	36.47	35.1	90.4	0.81	180.3	2.1	2.1	7.2	0.4894	73	211
EM2-200LB-6	22	30	980	44.3	42.09	40.6	90.9	0.83	214.4	2.1	2.1	7.3	0.552	73	225
EM2-225M-6	30	40	985	59.2	56.22	54.2	91.7	0.84	290.9	2	2.1	7.1	0.7063	74	298
EM2-250M-6	37	50	985	70.9	67.35	64.9	92.2	0.86	358.7	2.1	2.1	7.1	1.1189	76	369
EM2-280S-6	45	60	985	85.8	81.48	78.5	92.7	0.86	436.3	2.1	2	7.2	2.1645	78	462
EM2-280M-6	55	75	985	104	99.15	95.6	93.1	0.86	533.2	2.1	2	7.2	2.6692	78	515
EM2-315S-6	75	100	990	141	134.34	129	93.7	0.86	723.5	2	2	6.7	4.11	83	873
EM2-315M-6	90	125	990	169	160.70	155	94	0.86	868.2	2	2	6.7	4.8746	83	954
EM2-315LA-6	110	150	990	206	195.78	189	94.3	0.86	1061.1	2	2	6.7	5.9125	83	1024
EM2-315LB-6	132	180	990	244	231.50	223	94.6	0.87	1273.3	2	2	6.7	6.9504	83	1108
EM2-355MA-6	160	220	990	291	276.84	267	94.8	0.88	1543.4	2	2	6.7	9.9993	85	1511
EM2-355MB-6	200	270	990	363	345.32	333	95	0.88	1929.3	2	2	6.7	11.1898	85	1633
EM2-355LB-6	250	340	990	454	431.64	416	95	0.88	2411.6	2	2	6.7	14.0614	85	1735

**CAST IRON - IE2 8 POLE**

Motor Type	Rated Output		Rated Speed rpm	IFL 380V (AMP)	IFL 400V (AMP)	IFL 415V (AMP)	EFF %	Power Factor	Rated Torque Nm	Locked Rotor Torque TST/ TFL	Maximum Torque TM/ TFL	Locked Rotor Current IST/ IFL	M of J kgm2	Noise Level LW dB(A)	Net Weight kg
	kW	HP													
EM2-100LA-8	0.75	1	690	2.57	2.44	2.35	66.2	0.67	10.4	1.8	2	6.1	0.008	59	31
EM2-100LB-8	1.1	1.5	690	3.42	3.25	3.13	70.8	0.69	15.2	1.8	2	6.1	0.01	59	33
EM2-112M-8	1.5	2	690	4.39	4.17	4.02	74.1	0.7	20.8	1.8	2	6.4	0.017	61	41
EM2-132S-8	2.2	3	710	6.07	5.76	5.56	77.6	0.71	29.6	1.8	2	6.4	0.0131	64	64
EM2-132M-8	3	4	710	7.81	7.41	7.15	80	0.							

# DIMENSIONAL DRAWING

## CAST IRON - IE3 & IE4

\*all dimenions are measured in mm

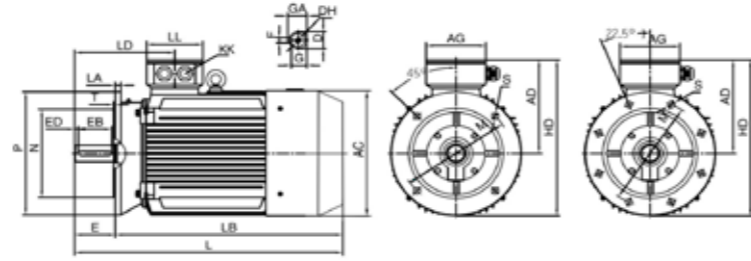

FLANGE MOUNTED B5

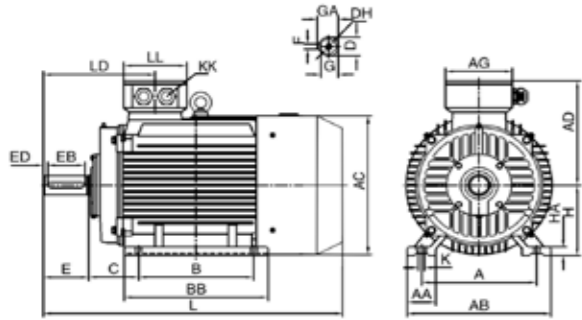

FOOT MOUNTED B3

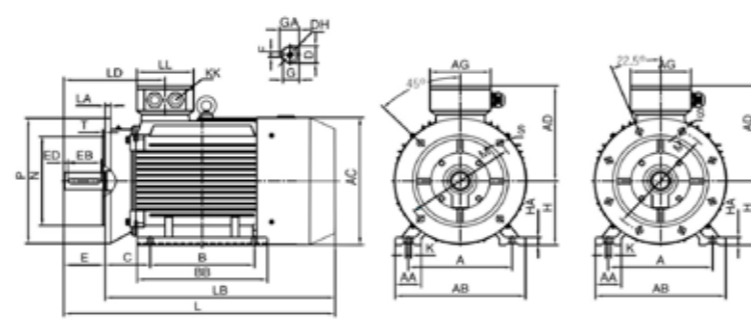

FOOT & FLANGE MOUNTED B35

Frame Size	A	AA	AB	AC	AD	AG	B	BB	C	D	DH	E	ED	EB	F	G	GA	H	HA	K	KK	L	LA	LB	LD	LL	M	N	P	S	T	
80	125	34	160	175	150	118	100	130	50	19	M6X16	40	22	5	6	15.5	21.5	80	10	10	M20*1.5	295	12	255	140	118	165	130	200	12	3.5	
90S/L	140	36	180	190	165	118	100/125	135/160	56	24	M8X19	50	32	5	8	20	27	90	12.5	10	M20*1.5	320/345	12	270/295	156	118	165	130	200	12	3.5	
100	160	40	200	215	170	118	140	182	63	28	M10X22	60	40	5	8	24	31	100	14	12	M25*1.5	345	14	285	193	118	215	180	250	14.5	4	
112	190	45	230	236	187	118	140	195	70	28	M10X22	60	40	5	8	24	31	112	14	12	M25*1.5	385	14	325	200	118	215	180	250	14.5	4	
132S/M	216	52	265	275	215	118	140/178	205/245	89	38	M12X28	80	56	5	10	33	41	132	16	12	M25*1.5	410/480	14	330/400	239	118	265	230	300	14.5	4	
160M/L	254	67	320	330	265	183	210/254	260/305	108	42	M16X36	110	80	7.5	12	37	45	160	19	14.5	M32*1.5	610/655	15	500/545	270	185	300	250	350	18.5	5	
180M/L	279	74	350	380	280	183	241/279	297/335	121	48	M16X36	110	80	7.5	14	42.5	51.5	180	22	14.5	M32*1.5	680/720	15	570/610	277	185	300	250	350	18.5	5	
200L	318	85	395	420	315	249	305	370	133	55	M20X42	100	90	7.5	16	49	59	200	25	18.5	M40*1.5	760	17	660	298	210	350	300	400	18.5	5	
225S	4,6,8	356	80	436	465	325	249	286	355	149	60	M20X42	140	80	10	18	53	64	225	28	18.5	M40*1.5	825	19	685	338	210	400	350	450	18.5	5
225M	2	356	80	436	465	325	249	311	380	149	55	M20X42	110	100	10	16	49	59	225	28	18.5	M40*1.5	820	19	710	338	210	400	350	450	18.5	5
	4,6,8	356	80	436	465	325	249	311	380	149	60	M20X42	140	100	10	18	53	64	225	28	18.5	M40*1.5	850	19	710	338	210	400	350	450	18.5	5
250M	2	406	88	495	520	370	275	349	440	168	60	M20X42	140	100	10	18	53	64	250	33	24	M50*1.5	925	20	785	360	238	500	450	550	18.5	5
	4,6,8	406	88	495	520	370	275	349	440	168	65	M20X42	140	100	10	18	58	69	250	33	24	M50*1.5	925	20	785	360	238	500	450	550	18.5	5
280S/M	2	457	109	550	570	405	275	368/419	535	190	65	M20X42	140	100	10	18	58	69	280	35	24	M50*1.5	975	22	835	344	238	500	450	550	18.5	5
	4,6,8	457	109	550	570	405	275	368/419	535	190	75	M20X42	140	100	10	20	67.5	79.5	280	35	24	M50*1.5	1000	22	860	344	238	500	450	550	18.5	5
315S	2	508	120	635	650	505	460	406	515	216	65	M20X42	140	100	10	18	58	69	315	45	28	M63*1.5	1160	24	1020	417	317	600	550	660	24	6
	4,6,8	508	120	635	650	505	460	406	515	216	80	M20X42	170	140	10	22	71	85	315	45	28	M63*1.5	1270	24	1100	417	317	600	550	660	24	6
315M/L	2	508	120	635	650	505	460	457/508	625	216	65	M20X42	140	100	10	18	58	69	315	45	28	M63*1.5	1270	24	1130	417	317	600	550	660	24	6
	4,6,8	508	120	635	650	505	460	457/508	625	216	80	M20X42	170	140	10	22	71	85	315	45	28	M63*1.5	1300	24	1130	417	317	600	550	660	24	6
355M/L	2	610	125	735	735	645	600	560/630	775	254	75	M20X42	140	100	10	20	67.5	79.5	355	49	28	M63*1.5	1530	25	1390	450	400	740	680	800	24	6
	4,6,8	610	125	735	735	645	600	560/630	775	254	95	M20X42	170	140	10	25	86	100	355	49	28	M63*1.5	1570	25	1400	450	400	740	680	800	24	6

## CAST IRON - IE3 2 POLE

Motor Type	Rated Output		Rated Speed rpm	IFL 380V (AMP)	IFL 400V (AMP)	IFL 415V (AMP)	EFF %	Power Factor	Rated Torque Nm	Locked Rotor Torque TST/ TFL	Maximum Torque TM/ TFL	Locked Rotor Current IST/ IFL	M of J kgm2	Noise Level LW dB(A)	Net Weight kg
	kW	HP													
EM3-80A-2	0.75	1	2855	1.72	1.64	1.58	80.7	0.82	2.5	2.3	2.3	6.8	0.001	67	17
EM3-80B-2	1.1	1.5	2860	2.43	2.31	2.23	82.7	0.83	3.7	2.3	2.3	7.3	0.0013	67	18
EM3-90S-2	1.5	2	2865	3.22	3.06	2.95	84.2	0.84	5.0	2.3	2.3	7.6	0.0024	72	23
EM3-90L-2	2.2	3	2870	4.58	4.35	4.19	85.9	0.85	7.3	2.3	2.3	7.8	0.0028	72	26
EM3-100L-2	3	4	2890	6.02	5.71	5.51	87.1	0.87	9.9	2.3	2.3	8.1	0.0074	76	32
EM3-112M-2	4	5.5	2900	7.84	7.45	7.18	88.1	0.88	13.2	2.3	2.3	8.3	0.0085	77	45
EM3-132SA-2	5.5	7.5	2910	10.6	10.11	9.75	89.2	0.88	18.0	2.2	2.3	8	0.0209	80	63
EM3-132SB-2	7.5	10	2910	14.4	13.65	13.2	90.1	0.88	24.6	2.2	2.3	7.8	0.0285	80	67
EM3-160MA-2	11	15	2930	20.6	19.56	18.9	91.2	0.89	35.9	2.2	2.3	7.9	0.0536	86	115
EM3-160MB-2	15	20	2930	27.9	26.47	25.5	91.9	0.89	48.9	2.2	2.3	8	0.058	86	118
EM3-160L-2	18.5	25	2935	34.2	32.47	31.3	92.4	0.89	60.2	2.2	2.3	8.1	0.0674	86	147
EM3-180M-2	22	30	2940	40.5	38.49	37.1	92.7	0.89	71.5	2.2	2.3	8.2	0.1505	89	173
EM3-200LA-2	30	40	2950	54.9	52.15	50.3	93.3	0.89	97.1	2.2	2.3	7.5	0.2064	92	241
EM3-200LB-2	37	50	2950	67.4	64.04	61.7	93.7	0.89	119.8	2.2	2.3	7.5	0.2249	92	257
EM3-225M-2	45	60	2970	80.8	76.78	74.0	94	0.9	144.7	2.2	2.3	7.6	0.52	92	318
EM3-250M-2	55	75	2975	98	93.54	90.2	94.3	0.9	176.6	2.2	2.3	7.6	0.5554	93	394
EM3-280S-2	75	100	2975	134	127.02	122	94.7	0.9	240.8	2.0	2.3	6.9	1.25	94	535
EM3-280M-2	90	125	2975	160	151.94	146	95	0.9	288.9	2.0	2.3	7	1.42	94	548
EM3-315S-2	110	150	2980	195	185.31	179	95.2	0.9	352.5	2.0	2.2	7.1	1.53	96	914
EM3-315M-2	132	180	2980	234	221.91	214	95.4	0.9	423.0	2.0	2.2	7.1	1.78	96	993
EM3-315LA-2	160	220	2980	279	265.47	256	95.6	0.91	512.8	2.0	2.2	7.1	2.16	99	1049
EM3-315LB-2	200	270	2980	349	331.14	319	95.8	0.91	640.9	2.0	2.2	7.1	4.54	99	1180
EM3-355MB-2	250	340	2980	436	413.93	399	95.8	0.91	801.2	2.0	2.2	7.1	6.31	103	1969
EM3-355L-2	315	430	2980	549	521.55	503	95.8	0.91	1009.5	2.0	2.2	7.1	6.97	103	2328

## CAST IRON - IE3 4 POLE

Motor Type	Rated Output		Rated Speed rpm	IFL 380V (AMP)	IFL 400V (AMP)	IFL 415V (AMP)	EFF %	Power Factor	Rated Torque Nm	Locked Rotor Torque TST/ TFL	Maximum Torque TM/ TFL	Locked Rotor Current IST/ IFL	M of J kgm2	Noise Level LW dB(A)	Net Weight kg
	kW	HP													
EM3-80B-4	0.75	1	1420	1.84	1.75	1.69	82.5	0.75	5.0	2.3	2.3	6.5	0.0035	58	18
EM3-90S-4	1.1	1.5	1425	2.61	2.48	2.39	84.1	0.76	7.4	2.3	2.3	6.6	0.0046	61	21
EM3-90L-4	1.5	2	1425	3.47	3.30	3.18	85.3	0.77	10.1	2.3	2.3	6.9	0.005	61	26
EM3-100LA-4	2.2	3	1440	4.76	4.52	4.36	86.7	0.81	14.6	2.3	2.3	7.5	0.0105	64	32
EM3-100LB-4	3	4	1440	6.34	6.02	5.80	87.7	0.82	19.9	2.3	2.3	7.6	0.0146	64	34
EM3-112M-4	4	5.5	1440	8.37	7.95	7.66	88.6	0.82	26.5	2.3	2.3	7.7	0.0188	65	46
EM3-132S-4	5.5	7.5	1450	11.2	10.68	10.3	89.6	0.83	36.2	2	2.3	7.5	0.0543	71	58
EM3-132M-4	7.5	10	1450	15.0	14.26	13.7	90.4	0.84	49.4	2.2	2.3	7.4	0.065	71	71
EM3-160M-4	11	15</													

**CAST IRON - IE3 6 POLE**

Motor Type	Rated Output		Rated Speed rpm	IFL 380V (AMP)	IFL 400V (AMP)	IFL 415V (AMP)	EFF %	Power Factor	Rated Torque Nm	Locked Rotor Torque TST/ TFL	Maximum Torque TM/ TFL	Locked Rotor Current IST/ IFL	M of J kgm2	Noise Level LW dB(A)	Net Weight kg
	kW	HP													
EM3-90S-6	0.75	1	945	2.03	1.93	1.86	78.9	0.71	7.6	2.1	2.1	5.8	0.0055	57	22
EM3-90L-6	1.1	1.5	945	2.83	2.69	2.59	81	0.73	11.1	2.1	2.1	5.9	0.007	57	26
EM3-100L-6	1.5	2	955	3.78	3.60	3.47	82.5	0.73	15.0	2.1	2.1	6	0.0128	61	32
EM3-112M-6	2.2	3	955	5.36	5.09	4.91	84.3	0.74	22.0	2	2.1	6	0.0225	65	44
EM3-132S-6	3	4	965	7.20	6.84	6.59	85.6	0.74	29.7	2	2.1	6.2	0.0435	69	64
EM3-132MA-6	4	5.5	965	9.46	8.99	8.66	86.8	0.74	39.6	2	2.1	6.8	0.0521	69	70
EM3-132MB-6	5.5	7.5	965	12.7	12.03	11.6	88	0.75	54.4	2	2.1	7.1	0.065	69	81
EM3-160M-6	7.5	10	970	16.2	15.38	14.8	89.1	0.79	73.8	2.1	2.1	6.7	0.1422	73	117
EM3-160L-6	11	15	970	23.1	21.98	21.2	90.3	0.8	108.3	2.1	2.1	6.9	0.1755	73	133
EM3-180L-6	15	20	980	30.9	29.31	28.2	91.2	0.81	146.2	2	2.1	7.2	0.34	73	169
EM3-200LA-6	18.5	25	980	37.8	35.95	34.7	91.7	0.81	180.3	2.1	2.1	7.2	0.3812	76	222
EM3-200LB-6	22	30	980	44.8	42.52	41.0	92.2	0.81	214.4	2.1	2.1	7.3	0.4491	76	237
EM3-225M-6	30	40	985	59.1	56.16	54.1	92.9	0.83	290.9	2	2.1	7.1	0.9856	76	313
EM3-250M-6	37	50	985	71.7	68.14	65.7	93.3	0.84	358.7	2.1	2.1	7.1	1.35	78	389
EM3-280S-6	45	60	990	85.8	81.55	78.6	93.7	0.85	434.1	2.1	2	7.2	2.47	80	482
EM3-280M-6	55	75	990	103	98.10	94.6	94.1	0.86	530.6	2.1	2	7.2	2.65	80	536
EM3-315S-6	75	100	990	143	136.23	131	94.6	0.84	723.5	2	2	6.7	3.49	85	895
EM3-315M-6	90	125	990	170	161.05	155	94.9	0.85	868.2	2	2	6.7	4.12	85	978
EM3-315LA-6	110	150	990	207	196.42	189	95.1	0.85	1061.1	2	2	6.7	9.31	85	1050
EM3-315LB-6	132	180	990	244	232.23	224	95.4	0.86	1273.3	2	2	6.7	10.5	85	1135
EM3-355MA-6	160	220	990	296	280.90	271	95.6	0.86	1543.4	2	2	6.7	11.4	92	1542
EM3-355MB-6	200	270	990	365	346.37	334	95.8	0.87	1929.3	2	2	6.7	13.5	92	1667
EM3-355LB-6	250	340	990	456	432.96	417	95.8	0.87	2411.6	2	2	6.7	14.4	92	1771

**CAST IRON - IE3 8 POLE**

Motor Type	Rated Output		Rated Speed rpm	IFL 380V (AMP)	IFL 400V (AMP)	IFL 415V (AMP)	EFF %	Power Factor	Rated Torque Nm	Locked Rotor Torque TST/ TFL	Maximum Torque TM/ TFL	Locked Rotor Current IST/ IFL	M of J kgm2	Noise Level LW dB(A)	Net Weight kg
	kW	HP													
EM3-100LA-8	0.75	1	695	2.27	2.15	2.08	75	0.67	10.3	1.8	2	6.2	0.008	59	32
EM3-100LB-8	1.1	1.5	695	3.12	2.96	2.85	77.7	0.69	15.1	1.8	2	6.2	0.01	59	34
EM3-112M-8	1.5	2	695	4.09	3.88	3.74	79.7	0.7	20.6	1.8	2	6.7	0.017	61	43
EM3-132S-8	2.2	3	715	5.75	5.46	5.26	81.9	0.71	29.4	1.8	2	6.7	0.0131	64	68
EM3-132M-8	3	4	715	7.48	7.10	6.85	83.5	0.73	40.1	1.8	2	6.9	0.04	64	83
EM3-160MA-8	4	5.5	725	9.82	9.33	8.99	84.8	0.73	52.7	1.9	2	6.9	0.075	68	100
EM3-160MB-8	5.5	7.5	725	13.1	12.45	12.0	86.2	0.74	72.4	1.9	2	6.9	0.093	68	114
EM3-160L-8	7.5	10	725	17.4	16.53	15.9	87.3	0.75	98.8	1.9	2	6.6	0.126	68	133
EM3-180L-8	11	15	735	25.2	23.89	23.0	88.6	0.75	142.9	2	2	6.6	0.203	70	181
EM3-200L-8	15	20	735	33.5	31.80	30.6	89.6	0.76	194.9	2	2	6.8	0.339	73	250
EM3-225S-8	18.5	25	735	41.0	39.00	37.6	90.1	0.76	240.3	1.9	2	6.8	0.491	73	283
EM3-225M-8	22	30	745	47.3	44.94	43.3	90.6	0.78	282.0	1.9	2	7	0.547	73	306
EM3-250M-8	30	40	745	63.2	60.04	57.9	91.3	0.79	384.5	1.9	2	6.7	0.83	75	389
EM3-280S-8	37	50	745	77.5	73.64	71.0	91.8	0.79	474.2	1.9	2	6.7	1.39	76	512
EM3-280M-8	45	60	745	93.9	89.18	86.0	92.2	0.79	576.8	1.9	2	6.7	1.65	76	568
EM3-315S-8	55	75	745	112	105.96	102	92.5	0.81	705.0	1.8	2	6.8	4.79	82	856
EM3-315M-8	75	100	745	151	143.56	138	93.1	0.81	961.3	1.8	2	6.3	5.58	82	948
EM3-315LA-8	90	125	745	179	169.62	163	93.4	0.82	1153.6	1.8	2	6.4	6.37	82	1035
EM3-315LB-8	110	150	745	218	206.65	199	93.7	0.82	1409.9	1.8	2	6.4	7.23	82	1048
EM3-355M-8	132	180	745	260	247.19	238	94	0.82	1691.9	1.8	2	6.5	7.6	89	1771
EM3-355MA-8	160	220	745	314	298.67	288	94.3	0.82	2050.8	1.8	2	6.6	11.73	89	1927
EM3-355L-8	200	270	745	387	367.67	354	94.6	0.83	2563.5	1.8	2	6.6	12.48	89	2010

**CAST IRON - IE4 2 POLE**

Motor Type	Rated Output		Rated Speed rpm	IFL 380V (AMP)	IFL 400V (AMP)	IFL 415V (AMP)	EFF %	Power Factor	Rated Torque Nm	Locked Rotor Torque TST/ TFL	Maximum Torque TM/ TFL	Locked Rotor Current IST/ IFL	M of J kgm2	Noise Level LW dB(A)	Net Weight kg
	kW	HP													
EM4-80A-2	0.75	1	2855	1.62	1.54	1.48	84.9	0.83	2.5	2.3	2.3	6.8	0.001	62	19
EM4-80B-2	1.1	1.5	2860	2.32	2.21	2.13	86.7	0.83	3.7	2.3	2.3	7.1	0.002	62	20
EM4-90S-2	1.5	2	2875	3.06	2.91	2.81	87.5	0.85	5.0	2.3	2.3	7.3	0.002	67	23
EM4-90L-2	2.2	3	2875	4.36	4.14	3.99	89.1	0.86	7.3	2.3	2.3	7.6	0.003	67	32
EM4-100L-2	3	4	2880	5.84	5.55	5.35	89.7	0.87	9.9	2.2	2.3	7.8	0.006	74	45
EM4-112M-2	4	5.5	2880	7.65	7.27	7.00	90.3	0.88	13.3	2.2	2.3	8.1	0.009	77	50
EM4-132SA-2	5.5	7.5	2900	10.4	9.86	9.50	91.5	0.88	18.1	2.2	2.3	8.2	0.024	79	85
EM4-132SB-2	7.5	10	2900	13.9	13.21	12.7	92.1	0.89	24.7	2.2	2.3	7.8	0.029	79	91
EM4-160MA-2	11	15	2940	20.2	19.18	18.5	93	0.89	35.7	2.2	2.3	7.9	0.067	81	134
EM4-160MB-2	15	20	2940	27.4	26.05	25.1	93.4	0.89	48.7	2.2	2.3	7.9	0.08	81	150
EM4-160L-2	18.5	25	2940	37.7	31.99	30.8	93.8	0.89	60.1	2.2	2.3	8	0.097	81	170
EM4-180M-2	22	30	2955	39.8	37.80	36.4	94.4	0.89	71.1	2.2	2.3	8.1	0.137	83	244
EM4-200LA-2	30	40	2965	54.2	51.49	49.6	94.5	0.89	96.6	2.0	2.3	7.5	0.227	84	329
EM4-200LB-2	37	50	2965	66.6	63.30	61.0	94.8	0.89	119.2	2.0	2.3	7.5	0.269	84	345
EM4-225M-2	45	60	2970	80.8	76.74	74.0	95.1	0.89	144.7	2.2	2.3	8.8	0.36	86	436
EM4-250M-2	55	75	2975	98.4	93.50	90.1	95.4	0.89	176.6	2.2	2.3	7.5	0.791	89	546
EM4-280S-2	75	100	2975	132	125.82	121	95.6	0.9	240.8	1.8	2.3	6.9	0.96	91	681
EM4-280M-2	90	125	2975	159	150.67	145	95.8	0.9	288.9	1.8	2.2	6.9	1.157	91	731
EM4-315S-2	110	150	2980	193	183.77	177	96	0.9	352.5	1.8	2.2	7	1.662	92	1296
EM4-315M-2	132	180	2980	232	220.52	213	96	0.9	423.0	1.8	2.2	7	1.874	92	1369
EM4-315LA-2	160	220	2980	278	263.81	254	96.2	0.91	512.8	1.8	2.2	7.1	2.146	92	1463
EM4-315LB-2	200	270	2980	347	329.42	318	96.3	0.91	640.9	1.8	2.2	7.1	2.448	92	1544
EM4-355MB-2	250	340	2980	433	411.35	396	96.4	0.91	801.2	1.6	2.2	7.1	4.4	100	1830
EM4-355L-2	315	430	2980	545	517.77	499	96.5	0.91	1009.5	1.6	2.2	7.2	5	100	2160

**CAST IRON - IE4 4 POLE**

Motor Type	Rated Output		Rated Speed rpm	IFL 380V (AMP)	IFL 400V (AMP)	IFL 415V (AMP)	EFF %	Power Factor	Rated Torque Nm	Locked Rotor Torque TST/ TFL	Maximum Torque TM/ TFL	Locked Rotor Current IST/ IFL	M of J kgm2	Noise Level LW dB(A)	Net Weight kg
	kW	HP													
EM4-80B-4	0.75	1	1400	1.80	1.71	1.65	85.6	0.74	5.1	2.3	2.3	6.4	0.003	56	20
EM4-90S-4	1.1	1.5	1425	2.55	2.42	2.33	87.4	0.75	7.4	2.3	2.3	6.6	0.004	59	27
EM4-90L-4	1.5	2	1425	3.32	3.15	3.04	88.1	0.78	10.1	2.3	2.3	6.7	0.005	59	30
EM4-100LA-4	2.2	3	1440	4.68	4.44	4.28	89.7	0.797	14.6	2.3	2.3	7.3	0.012	64	41
EM4-100LB-4	3	4	1440	6.31	5.99	5.78	90.3	0.8	19.9	2.3	2.3	7.5	0.016	64	46
EM4-112M-4	4	5.5	1450	8.36	7.94	7.65	90.9	0.8	26.3	2.3	2.3	7.5	0.022	65	54
EM4-132S-4	5.5	7.5	1455	11.20	10.64	10.26	92.1	0.81	36.1	2	2.3	7.5	0.06	71	100
EM4-132M-4															

CAST IRON - IE4 6 POLE

Motor Type	Rated Output		Rated Speed rpm	IFL 380V (AMP)	IFL 400V (AMP)	IFL 415V (AMP)	EFF %	Power Factor	Rated Torque Nm	Locked Rotor Torque TST/ TFL	Maximum Torque TM/ TFL	Locked Rotor Current IST/ IFL	M of J kgm2	Noise Level LW dB(A)	Net Weight kg
	kW	HP													
EM4-90S-6	0.75	1	935	1.96	1.86	1.79	83.1	0.7	7.7	2	2.1	5.8	0.004	57	25
EM4-90L-6	1.1	1.5	940	2.80	2.66	2.56	84.1	0.71	11.2	2	2.1	5.9	0.006	57	30
EM4-100L-6	1.5	2	945	3.72	3.54	3.41	86.2	0.71	15.2	2	2.1	5.9	0.016	61	40
EM4-112M-6	2.2	3	950	5.33	5.06	4.88	87.1	0.72	22.1	2	2.1	6.2	0.039	65	46
EM4-132S-6	3	4	960	7.14	6.78	6.54	88.7	0.72	29.8	2	2.1	6.4	0.035	69	83
EM4-132MA-6	4	5.5	960	8.26	7.85	7.57	89.7	0.82	39.8	2	2.1	6.6	0.043	69	95
EM4-132MB-6	5.5	7.5	960	12.5	12.15	11.71	89.5	0.73	54.7	2	2.1	6.8	0.056	69	110
EM4-160M-6	7.5	10	970	16.0	15.19	14.6	90.2	0.79	73.8	2	2.1	6.8	0.14	73	146
EM4-160L-6	11	15	970	23.1	21.97	21.2	91.5	0.79	108.3	2	2.1	6.9	0.192	73	168
EM4-180L-6	15	20	975	30.8	29.26	28.2	92.5	0.8	146.9	2	2.1	7.3	0.319	73	204
EM4-200LA-6	18.5	25	975	37.7	35.85	34.6	93.1	0.8	181.2	2	2.1	7.2	0.446	73	308
EM4-200LB-6	22	30	975	43.9	41.75	40.2	93.9	0.81	215.5	2	2.1	7.3	0.557	73	326
EM4-225M-6	30	40	985	58.9	56.00	54.0	94.3	0.82	290.9	2	2.1	6.8	0.832	74	397
EM4-250M-6	37	50	985	71.6	68.02	65.6	94.6	0.83	358.7	2	2.1	7	1.447	76	477
EM4-280S-6	45	60	985	84.8	80.52	77.6	94.9	0.85	436.3	2	2	7.2	2.252	78	702
EM4-280M-6	55	75	985	102	96.97	93.5	95.2	0.86	533.2	2	2	7.2	2.726	83	763
EM4-315S-6	75	100	990	142	135.09	130	95.4	0.84	723.5	2	2	6.5	3.984	83	1265
EM4-315M-6	90	125	990	168	159.87	154	95.6	0.85	868.2	2	2	6.6	4.5	83	1334
EM4-315LA-6	110	150	990	206	195.39	188	95.6	0.85	1061.1	2	2	6.6	5.607	83	1465
EM4-315LB-6	132	180	990	243	231.26	223	95.8	0.86	1273.3	2	2	6.7	6.935	83	1525
EM4-355MA-6	160	220	990	294	279.73	270	96	0.86	1543.4	1.8	2	6.8	11.9	85	1680
EM4-355MB-6	200	270	990	363	345.29	333	96.1	0.87	1929.3	1.8	2	6.8	13.5	85	1810
EM4-355LB-6	250	340	990	454	431.61	416	96.1	0.87	2411.6	1.8	2	6.8	14.3	85	1960

CAST IRON - IE4 8 POLE

Motor Type	Rated Output		Rated Speed rpm	IFL 380V (AMP)	IFL 400V (AMP)	IFL 415V (AMP)	EFF %	Power Factor	Rated Torque Nm	Locked Rotor Torque TST/ TFL	Maximum Torque TM/ TFL	Locked Rotor Current IST/ IFL	M of J kgm2	Noise Level LW dB(A)	Net Weight kg
	kW	HP													
EM4-100LA-8	0.75	1	690	2.20	2.09	2.02	78.4	0.66	10.4	2	2	7	0.008	59	35
EM4-100LB-8	1.1	1.5	690	3.09	2.93	2.83	80.8	0.67	15.2	2	2	7	0.01	59	41
EM4-112M-8	1.5	2	690	4.00	3.80	3.66	82.6	0.69	20.8	2	2	7	0.017	61	46
EM4-132S-8	2.2	3	710	5.65	5.37	5.17	84.5	0.7	29.6	1.8	2	7.5	0.031	64	60
EM4-132M-8	3	4	710	7.45	7.10	6.84	85.9	0.71	40.3	1.8	2	7.8	0.04	64	69
EM4-160MA-8	4	5.5	720	9.69	9.21	8.9	87.1	0.72	53.1	1.8	2	7.9	0.075	68	104
EM4-160MB-8	5.5	7.5	720	13.0	12.32	11.9	88.3	0.73	72.9	1.8	2	8.1	0.093	68	122
EM4-160L-8	7.5	10	720	17.2	16.38	15.8	89.3	0.74	99.5	1.8	2	7.8	0.126	68	139
EM4-180L-8	11	15	730	25.0	23.73	22.9	90.4	0.74	143.9	1.8	2	7.9	0.203	70	174
EM4-200L-8	15	20	730	33.3	31.65	30.5	91.2	0.75	196.2	1.8	2	8	0.339	73	249
EM4-225S-8	18.5	25	730	40.9	38.83	37.4	91.7	0.75	242.0	1.8	2	8.1	0.491	73	307
EM4-225M-8	22	30	740	47.1	44.78	43.2	92.1	0.77	283.9	1.8	2	8.3	0.547	73	341
EM4-250M-8	30	40	740	63.0	59.89	58	92.7	0.78	387.1	1.8	2	7.9	0.83	75	440
EM4-280S-8	37	50	740	77.4	73.54	71	93.1	0.78	477.5	1.8	2	7.9	1.4	76	561
EM4-280M-8	45	60	740	93.9	89.16	86	93.4	0.78	580.7	1.8	2	7.9	1.65	76	660
EM4-315S-8	55	75	740	111	105.91	102	93.7	0.8	709.7	1.8	2	8.2	4.79	82	868
EM4-315M-8	75	100	740	149	141.88	137	94.2	0.81	967.8	2	2	7.6	5.58	82	938
EM4-315LA-8	90	125	740	177	167.82	162	94.4	0.82	1161.4	2	2	7.7	6.37	82	1158
EM4-315LB-8	110	150	740	215	204.47	197	94.7	0.82	1419.4	2	2	7.7	7.3	82	1366
EM4-355M-8	132	180	740	258	244.84	236	94.9	0.82	1703.3	2	2	7.7	12.5	89	1736
EM4-355MA-8	160	220	740	312	296.15	285	95.1	0.82	2064.6	2	2	7.7	12.9	89	2084
EM4-355L-8	200	270	740	384	364.58	351	95.4	0.83	2580.8	2	2	7.8	14.2	89	2142

# CLASS H MOTORS

## THREE-PHASE ASYNCHRONOUS MOTORS CAST IRON HOUSING

The Class H series of three-phase asynchronous motors are designed with a Totally Enclosed Fan Cooled (TEFC) construction and are available in both cast iron and aluminium housing. These motors are an enhancement over our standard induction motors and share the same technical data.

They are specifically designed to meet the High Temperature Resistance requirements and can endure an ambient temperature of up to 85 °C and an internal winding temperature of up to 300 °C for up to 2 hours. This is achieved through the use of higher temperature safety margins and enhancements made to our internal winding, among other things.

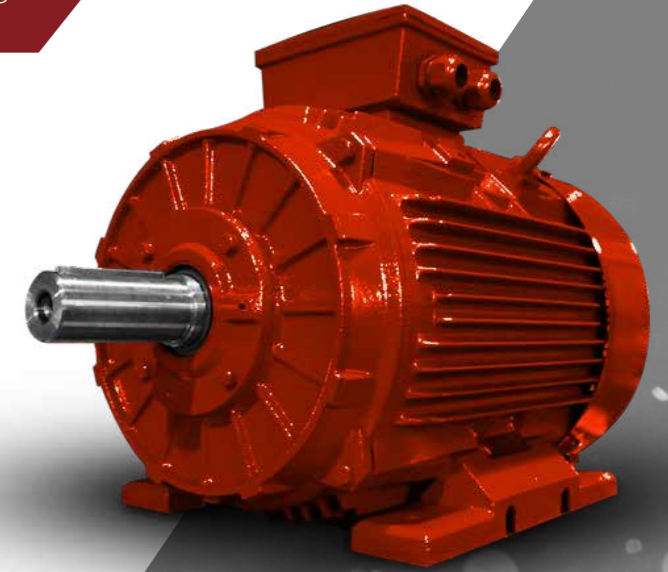

### CERTIFICATION

- Class H 180°C for 2 Hours
- Class H 300°C for 2 Hours
- Class H 250°C for 2 Hours
- Class H 400°C for 2 Hours



## DIMENSIONAL DRAWING

### ALUMINIUM - IE1 & IE3

\*all dimenions are measured in mm

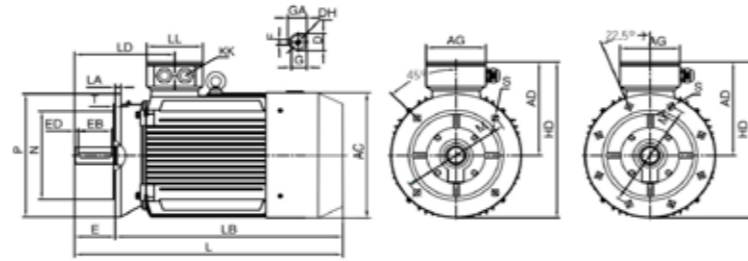

FLANGE MOUNTED B5

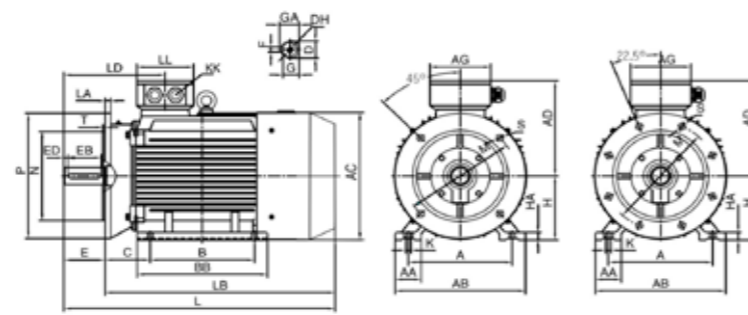

FOOT & FLANGE MOUNTED B35

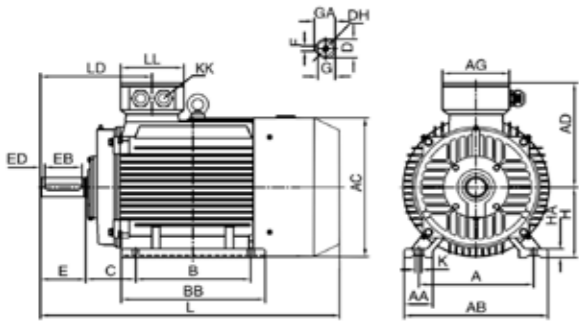

FOOT MOUNTED B3

Frame Size	A	AA	AB	AC	AD	AG	B	BA	BB	C	D	DH	E	EB	ED	F	G	GA	H	HA	K	KK	L	LA	LB	LD	LL	N	P	S	T
63	100	24	123	120	102	101	80	25.5	100	40	11	M4X12	23	16	3.5	4	8.5	12.5	63	7	7X9.5	M20*1.5	217	10	194	95.5	101	95	140	10	3
71	112	26	138	136	109	101	90	27.5	110	45	14	M5X12	30	25	2.5	5	11	16	71	8	7X11	M20*1.5	245	10	215	110.5	101	110	160	10	3.5
80	125	35	157	155	124	101	100	32.5	125	50	19	M6X16	40	30	5	6	15.5	21.5	80	9	10X14	M20*1.5	287	12	247	118	101	130	200	12	3.5
90S	140	37	173	175	137	109	100	32.5	125	56	24	M8X19	50	40	5	8	20	27	90	10	10X14	M20*1.5	310	11	260	136	109	130	200	12	3.5
90L	140	37	173	175	137	109	125	32.5	150	56	24	M8X19	50	40	5	8	20	27	90	10	10X14	M20*1.5	335	11	285	136	109	130	200	12	3.5
100L	160	40	196	195	151	109	140	39	172	63	28	M10X22	60	50	5	8	24	31	100	11	12X16	M20*1.5	383	13	323	144	109	180	250	14.5	4
112M	190	41	227	219	169	117.5	140	43	180	70	28	M10X22	60	50	5	8	24	31	112	12	12X16	M25*1.5	401	14	341	152	117.5	180	250	14.5	4
132S	216	51	262	258	188	117.5	140	46	186	89	38	M12X28	80	65	7.5	10	33	41	132	15	12X16	M25*1.5	475	14	395	180	117.5	230	300	14.5	4
132M	216	51	262	258	188	117.5	178	46	224	89	38	M12X28	80	65	7.5	10	33	41	132	15	12X16	M25*1.5	513	14	433	180	117.5	230	300	14.5	4
160M	254	55	304	315	242	167	210	50	260	108	42	M16X36	110	90	10	12	37	45	160	18	15X18	M32*1.5	609	15	499	268.5	157	250	350	18.5	5
160L	254	55	304	315	242	167	254	50	304	108	42	M16X36	110	90	10	12	37	45	160	18	15X18	M32*1.5	653	15	543	268.5	157	250	350	18.5	5

# ALUMINIUM MOTORS

## THREE-PHASE ASYNCHRONOUS MOTORS ALUMINIUM HOUSING

The Aluminum Motors series offers a variety of power outputs, ranging from 0.09 KW to 15 KW, with options of 2, 4, 6, and 8 poles. These motors are utilized in a wide range of industries, including blower fan, industrial fan, food and beverage, water and sewage, and air compressor. Advantages of aluminum over cast iron include a lighter weight due to the motor body's material composition, detachable motor feet, and a more polished appearance.



## TECHNICAL DATA

### ALUMINIUM - IE1 2 POLE

Motor Type	Rated Output		Rated Speed rpm	IFL 380V (AMP)	IFL 400V (AMP)	IFL 415V (AMP)	EFF %	Power Factor	Rated Torque Nm	Locked Rotor Torque TST/ TFL	Maximum Torque TM/ TFL	Locked Rotor Current IST/ IFL	M of J kgm2	Noise Level LW dB(A)	Net Weight kg
	kW	HP													
EM63A-2	0.18	0.25	2720	0.68	0.65	0.62	52.8	0.80	0.63	2.3	2.2	5.5	0.00567	61	4.3
EM63B-2	0.25	0.37	2720	0.85	0.80	0.77	58.2	0.81	0.88	2.3	2.2	5.5	0.00567	61	4.4
EM71A-2	0.37	0.5	2740	1.14	1.08	1.04	63.9	0.81	1.29	2.3	2.2	6.1	0.00832	64	5.3
EM71B-2	0.55	0.75	2740	1.55	1.47	1.42	69	0.82	1.92	2.2	2.3	6.1	0.00832	64	6.2
EM80A-2	0.75	1	2840	2.00	1.90	1.83	72.1	0.83	2.52	2.2	2.3	6.1	0.01071	62	8.7
EM80B-2	1.1	1.5	2840	2.79	2.65	2.55	75	0.84	3.7	2.2	2.3	6.9	0.01071	62	9.2
EM90S-2	1.5	2	2840	3.69	3.51	3.38	77.2	0.84	5.04	2.2	2.3	7	0.013984	67	12.8
EM90L-2	2.2	3	2840	5.18	4.92	4.74	79.7	0.85	7.4	2.2	2.3	7	0.015295	67	15
EM100L-2	3	4	2860	6.75	6.41	6.18	81.5	0.87	10.02	2.2	2.3	7.5	0.02145	74	20.2
EM112M-2	4	5.5	2880	8.73	8.29	7.99	83.1	0.88	13.3	2.2	2.3	7.5	0.029232	77	24
EM132SA-2	5.5	7.5	2900	12.0	11.4	11.0	84.7	0.86	18.1	2.2	2.3	7.5	0.039339	79	35.5
EM132SB-2	7.5	10	2900	15.8	15.0	14.5	86	0.88	24.7	2.2	2.3	7.5	0.04185	79	39.7

### ALUMINIUM - IE1 4 POLE

Motor Type	Rated Output		Rated Speed rpm	IFL 380V (AMP)	IFL 400V (AMP)	IFL 415V (AMP)	EFF %	Power Factor	Rated Torque Nm	Locked Rotor Torque TST/ TFL	Maximum Torque TM/ TFL	Locked Rotor Current IST/ IFL	M of J kgm2	Noise Level LW dB(A)	Net Weight kg
	kW	HP													
EM63A-4	0.12	0.18	1310	0.53	0.51	0.49	50	0.72	0.87	2.1	2.2	4.4	0.00567	52	4.2
EM63B-4	0.18	0.25	1310	0.69	0.66	0.63	57	0.73	1.31	2.1	2.2	4.4	0.00567	52	4.5
EM71A-4	0.25	0.37	1330	0.88	0.83	0.80	61.5	0.74	1.8	2.1	2.2	5.2	0.00832	55	5.3
EM71B-4	0.37	0.5	1330	1.19	1.13	1.09	66	0.75	2.66	2.1	2.2	5.2	0.00832	55	6.1
EM80A-4	0.55	0.75	1390	1.67	1.59	1.53	70	0.75	3.78	2.4	2.3	5.2	0.01071	56	8.1
EM80B-4	0.75	1	1390	2.18	2.07	2.00	72.1	0.76	5.15	2.3	2.3	6	0.01071	56	9.2
EM90S-4	1.1	1.5	1390	3.04	2.89	2.78	75	0.77	7.56	2.3	2.3	6	0.013984	59	12.3
EM90L-4	1.5	2	1390	3.97	3.78	3.64	77.2	0.78	10.2	2.3	2.3	6	0.015295	59	15.3
EM100LA-4	2.2	3	1390	5.44	5.16	4.98	79.7	0.81	15.1	2.3	2.3	7	0.02145	64	20
EM100LB-4	3	4	1410	7.16	6.80	6.56	81.5	0.82	20.3	2.3	2.3	7	0.02145	64	22.7
EM112M-4	4	5.5	1410	9.36	8.90	8.58	83.1	0.82	27.1	2.3	2.3	7	0.029232	65	24
EM132S-4	5.5	7.5	1435	12.5	11.9	11.4	84.7	0.83	36.6	2.3	2.3	7	0.039339	71	33
EM132M-4	7.5	10	1440	16.6	15.7	15.2	86	0.84	49.7	2.3	2.3	7	0.04185	71	48

### ALUMINIUM - IE1 6 POLE

Motor Type	Rated Output		Rated Speed rpm	IFL 380V (AMP)	IFL 400V (AMP)	IFL 415V (AMP)	EFF %	Power Factor	Rated Torque Nm	Locked Rotor Torque TST/ TFL	Maximum Torque TM/ TFL	Locked Rotor Current IST/ IFL	M of J kgm2	Noise Level LW dB(A)	Net Weight kg
	kW	HP													
EM71B-6	0.25	0.37	850	1.13	1.07	1.03	52.1	0.68	2.81	1.9	2	4	0.00832	52	6.7
EM80A-6	0.37	0.5	885	1.41	1.34	1.29	59.7	0.7	3.99	1.9	2	4.7	0.01071	54	8.5
EM80B-6	0.55	0.75	885	1.85	1.76	1.70	65.8	0.72	5.94	1.9	2.1	4.7	0.01071	54	9.4
EM90S-6	0.75	1	910	2.37	2.26	2.17	70	0.72	7.87	2	2.1	5.3	0.013984	57	12.4
EM90L-6	1.1	1.5	910	3.34	3.18	3.06	72.9	0.72	11.5	2	2.1	5.5	0.015295	57	15.6
EM100L-6	1.5	2	920	4.24	4.03	3.89	75.2	0.75	15.6	2	2.1	5.5	0.02145	61	20.5
EM112M-6	2.2	3	935	5.94	5.65	5.44	77.7	0.76	22.5	2	2.1	6.5	0.029232	65	25.2
EM132S-6	3	4	960	7.90	7.51	7.24	79.7	0.76	29.8	2.1	2.1	6.5	0.039339	69	38.5
EM132MA-6	4	5.5	960	10.3	9.80	9.45	81.4	0.76	39.8	2.1	2.1	6.5	0.04185	69	41.5
EM132MB-6	5.5	7.5	960	13.7	13.0	12.6	83.1	0.77	54.7	2.1	2.1	6.5	0.04185	69	45.7
EM160M-6	7.5	10	970	18.1	17.2	16.6	84.7	0.78	73.8	2	2.1	6.5	0.08316	73	69.5

### ALUMINIUM - IE3 2 POLE

Motor Type	Rated Output		Rated Speed rpm	IFL 380V (AMP)	IFL 400V (AMP)	IFL 415V (AMP)	EFF %	Power Factor	Rated Torque Nm	Locked Rotor Torque TST/ TFL	Maximum Torque TM/ TFL	Locked Rotor Current IST/ IFL	M of J kgm2	Noise Level LW dB(A)	Net Weight kg
	kW	HP													
EM3-80A-2	0.75	1	2880	1.81	1.72	1.66	80.7	0.82	2.49	2.3	2.3	7	0.01071	67	8.8
EM3-80B-2	1.1	1.5	2880	2.56	2.43	2.34	82.7	0.83	3.65	2.2	2.3	7.3	0.01071	67	9
EM3-90S-2	1.5	2	2895	3.38	3.21	3.09	84.2	0.84	4.95	2.2	2.3	7.6	0.013984	72	13.5
EM3-90L-2	2.2	3	2895	4.81	4.57	4.40	85.9	0.85	7.26	2.2	2.3	7.6	0.015295	72	17
EM3-100L-2	3	4	2895	6.32	6.00	5.79	87.1	0.87	9.9	2.2	2.3	7.8	0.02145	76	23.2
EM3-112M-2	4	5.5	2905	8.23	7.82	7.54	88.1	0.88	13.1	2.2	2.3	8.3	0.029232	77	40
EM3-132SA-2	5.5	7.5	2930	11.2	10.6	10.2	89.2	0.88	17.9	2	2.3	8.3	0.039339	80	42
EM3-132SB-2	7.5	10	2930	15.1	14.3	13.8	90.1	0.88	24.4	2	2.3	7.9	0.04185	80	48

### ALUMINIUM - IE3 4 POLE

Motor Type	Rated Output		Rated Speed rpm	IFL 380V (AMP)	IFL 400V (AMP)	IFL 415V (AMP)	EFF %	Power Factor	Rated Torque Nm	Locked Rotor Torque TST/ TFL	Maximum Torque TM/ TFL	Locked Rotor Current IST/ IFL	M of J kgm2	Noise Level LW dB(A)	Net Weight kg
	kW	HP													
EM3-80A-4	0.55	0.75	1400	1.45	1.38	1.33	80.8	0.75	3.75	2.4	2.3	5.2	0.01071	58	9.1
EM3-80B-4	0.75	1	1420	1.93	1.83	1.77	82.5	0.75	5.04	2.3	2.3	6.6	0.01071	58	11.1
EM3-90S-4	1.1	1.5	1445	2.75	2.61	2.52	84.1	0.76	7.27	2.3	2.3	6.8	0.013984	61	15
EM3-90L-4	1.5	2	1445	3.64	3.46	3.33	85.3	0.77	9.91	2.3	2.3	7	0.015295	61	19
EM3-100LA-4	2.2	3	1450	5.00	4.75	4.58	86.7	0.81	14.6	2.3	2.3	7.6	0.02145	64	25.4
EM3-100LB-4	3	4	1450	6.66	6.33	6.10	87.7	0.82	20	2.3	2.3	7.6	0.02145	64	30.5
EM3-112M-4	4	5.5	1450	8.78	8.34	8.04	88.6	0.82	26.5	2.3	2.3	7.8	0.029232	65	37
EM3-132S-4	5.5	7.5	1460	11.8	11.2	10.8	89.6	0.83	36	2	2.3	7.9	0.039339	71	48.5
EM3-132M-4	7.5	10	1460	15.8	15.0	14.4	90.4	0.84	49.1	2	2.3	7.5	0.04185	71	60

### ALUMINIUM - IE3 6 POLE

Motor Type	Rated Output		Rated Speed rpm	IFL 380V (AMP)	IFL 400V (AMP)	IFL 415V (AMP)	EFF %	Power Factor	Rated Torque Nm	Locked Rotor Torque TST/ TFL	Maximum Torque TM/ TFL	Locked Rotor Current IST/ IFL	M of J kgm2	Noise Level LW dB(A)	Net Weight kg
	kW	HP													
EM3-90S-6	0.75	1	935	2.14	2.03	1.96	78.9	0.71	7.66	2	2.1	6	0.013984	57	14
EM3-90L-6	1.1	1.5	945	2.97	2.82	2.72	81	0.73	11.1	2	2.1	6	0.015295	57	18
EM3-100L-6	1.5	2	949	3.97	3.77	3.64	82.5	0.73	15.1	2	2.1	6.5	0.02145	61	29.5
EM3-112M-6	2.2	3	955	5.63	5.35	5.16	84.3	0.74	22	2	2.1	6.6	0.029232	65	32
EM3-132S-6	3	4	968	7.56	7.18	6.92	85.6	0.74	29.6	2	2.1	6.8	0.039339	69	43
EM3-132MA-6	4	5.5	968	9.93	9.43	9.09	86.8	0.74	39.5	2	2.1	6.8	0.04185	69	49
EM3-132MB-6	5.5	7.5	968	13.3	12.6	12.2	88	0.75	54.3	2	2.1	7	0.04185	69	59
EM3-160M-6	7.5	10	970	17.0	16.2	15.6	89.1	0.79	73.8	2	2.1	7	0.08316	73	82

# DUAL SPEED MOTORS

## THREE-PHASE ASYNCHRONOUS MOTORS CAST IRON / ALUMINIUM HOUSING

The Dual Speed series of three-phase asynchronous motors are available in cast iron and aluminium housing and are Totally Enclosed Fan Cooled (TEFC). These motors have the ability to operate at various power outputs and speeds, offering a wide range of options.

They use unique winding technology to ensure dependable performance, easy maintenance, and a professional appearance, while producing minimal noise and vibration. These motors are commonly used in the fan and pump industry.

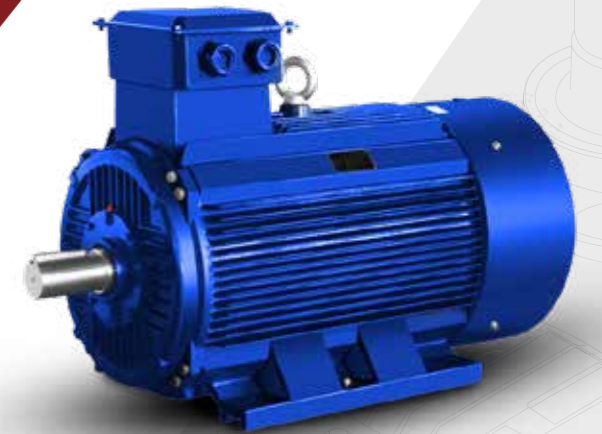

# TENV MOTORS

## THREE-PHASE ASYNCHRONOUS MOTORS ALUMINIUM HOUSING

The TENV series comprises of three-phase asynchronous motors that are Totally Enclosed Fan Cooled (TEFC). They are available in both cast iron and aluminium housing. These motors are a modified version of our standard induction motors and share the same technical data. TENV motors do not come with a fan blade and fan cover but include a 1-meter wire extension with a detached T-box as standard issue. These motors are suitable for fan duty applications.



# INVERTER MOTORS

## THREE-PHASE ASYNCHRONOUS MOTORS CAST IRON / ALUMINIUM HOUSING

The Inverter Duty Series of motors come in cast iron and aluminum housing and are Totally Enclosed Fan Cooled (TEFC). These motors are an improvement of our standard induction motors and have the same technical specifications.

Inverter duty motors can be used with any VFD/VSD brand and can operate continuously at frequencies ranging from 5Hz to 100Hz. They also come with a Force Cooling Fan, longer rotor and stator, and reinforced corona resistance as standard features.



## DIMENSIONAL DRAWING

### SINGLE PHASE MOTORS

\*all dimensions are measured in mm

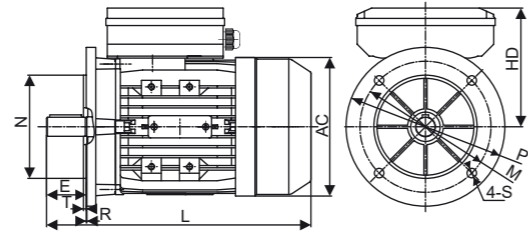

FLANGE MOUNTED B5

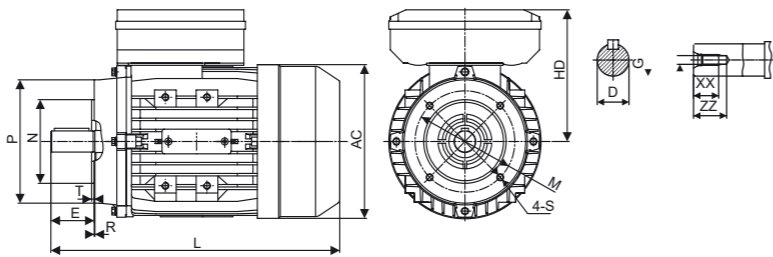

FOOT & FLANGE MOUNTED B35

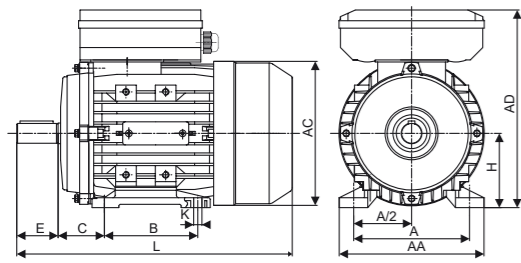

FOOT MOUNTED B3

# SINGLE PHASE MOTORS

## SINGLE-PHASE ASYNCHRONOUS MOTORS ALUMINIUM HOUSING

The Single Phase series of motors are equipped with either a single or dual capacitor. These motors are created with high-quality materials and adhere to IEC standards. They offer dependable operation, good performance, and safety, and are ideal for low voltage applications.

This series of motors is well-suited for use in air compressors, industrial fans and blowers, and various other small machinery.

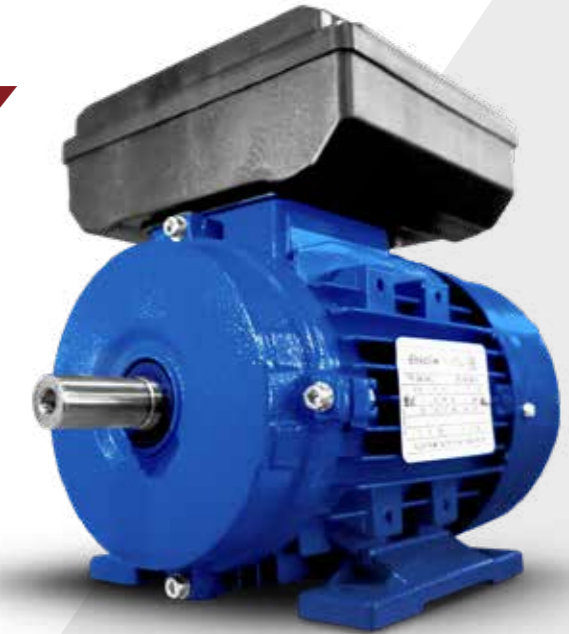

### SINGLE PHASE - SINGLE CAPACITOR

Frame	Installation Dimensions (mm)																				Overall Dimensions (mm)					
	IM B3										IM B14					IM B35					AB	AC	AD	HD	L	
	A	B	C	D	E	F	G	H	K	M	N	P	R	S	T	M	N	P	R	S						T
EMY 56	90	71	36	9	20	3	7.2	56	5.8	65	50	80	0	M5	2.5	100	80	120	0	7	3	110	108	88	144	198
EMY 63	100	80	40	11	23	4	8.5	63	7	75	60	90	0	M5	2.5	115	95	140	0	10	3	120	119	119	182	216
EMY 71	112	90	45	14	30	5	11	71	7	85	70	105	0	M6	2.5	130	110	160	0	10	3.5	132	137	126	197	250
EMY 80	125	100	50	19	40	6	15.5	80	10	100	80	120	0	M6	3.0	165	130	200	0	12	3.5	160	155	149	229	278
EMY 90S	140	125	56	24	50	8	20	90	10	115	95	140	0	M8	3.0	165	130	200	0	12	3.5	175	172	153	243	296
EMY 90L	140	125	56	24	50	8	20	90	10	115	95	140	0	M8	3.0	165	130	200	0	12	3.5	175	172	153	243	322
EMY 100L	160	140	63	28	60	8	24	100	12	130	110	160	0	M8	3.5	215	180	250	0	15	4.0	198	194	162	262	352

### SINGLE PHASE - DUAL CAPACITOR

Frame	Installation Dimensions (mm)																				Overall Dimensions (mm)					
	IM B3										IM B14					IM B35					AB	AC	AD	HD	L	
	A	B	C	D	E	F	G	H	K	M	N	P	R	S	T	M	N	P	R	S						T
EML 63	100	80	40	11	23	4	8.5	63	7	75	60	90	0	M5	2.5	115	95	140	0	10	3	120	119	118	181	231
EML 71	112	90	45	14	30	5	11	71	7	85	70	105	0	M6	2.5	130	110	160	0	10	3.5	132	137	125	196	250
EML 80	125	100	50	19	40	6	15.5	80	10	100	80	120	0	M6	3.0	165	130	200	0	12	3.5	160	155	146	226	278
EML 90S	140	100	56	24	50	8	20	90	10	115	95	140	0	M8	3	165	130	200	0	12	3.5	175	172	151	241	352
EML 90L	140	125	56	24	50	8	20	90	10	115	95	140	0	M8	3.0	165	130	200	0	12	3.5	175	172	151	241	352
EML 100L	160	140	63	28	60	8	24	100	12	130	110	160	0	M8	3.5	215	180	250	0	15	4.0	198	194	162	262	414
EML 112M	190	140	70	28	60	8	24	112	12	130	110	160	0	M8	3.5	215	180	250	0	15	4.0	220	217	186	298	424

## TECHNICAL DATA

### SINGLE PHASE - SINGLE CAPACITOR 2 POLE

Motor Type	Rated Output		Voltage (V)	Rated Current In(A)	Rated Speed (r/min)	Efficiency (%)	Full Load Power Factor (cos φ)	Ist (A)	Tst/Tn	Tmax/Tn	Net Weight IM B3 (kg)
	HP	KW									
EMY 56A-2	1/8	0.09	230	0.75	2800	56	0.92	3.0	0.5	1.7	2.5
EMY 56B-2	1/6	0.12	230	0.94	2800	60	0.92	4.0	0.5	1.7	3.0
EMY 63A-2	1/4	0.18	230	1.31	2800	65	0.92	5.0	0.4	1.7	4.2
EMY 63B-2	1/3	0.25	230	1.79	2800	66	0.92	7.0	0.4	1.7	4.5
EMY 71A-2	1/2	0.37	230	2.61	2800	67	0.92	10	0.35	1.7	5.7
EMY 71B-2	3/4	0.55	230	3.71	2800	70	0.92	15	0.35	1.7	6.7
EMY 80A-2	1	0.75	230	4.93	2800	72	0.92	20	0.33	1.7	9.3
EMY 80B-2	1.5	1.1	230	6.71	2800	75	0.95	30	0.33	1.7	10.6
EMY 90S-2	2	1.5	230	9.03	2800	76	0.95	40	0.30	1.7	13
EMY 90L-2	3	2.2	230	13.08	2800	77	0.95	65	0.30	1.7	16
EMY 100L-2	4	3	230	17.8	2800	79	0.95	92	0.30	1.7	25

### SINGLE PHASE - SINGLE CAPACITOR 4 POLE

Motor Type	Rated Output		Voltage (V)	Rated Current In(A)	Rated Speed (r/min)	Efficiency (%)	Full Load Power Factor (cos φ)	Ist (A)	Tst/Tn	Tmax/Tn	Net Weight IM B3 (kg)
	HP	KW									
EMY 56A-4	1/12	0.06	230	0.58	1400	50	0.90	2.0	0.45	1.7	2.8
EMY 56B-4	1/8	0.09	230	0.83	1400	52	0.90	3.0	0.45	1.7	3.4
EMY 63A-4	1/6	0.12	230	1.01	1400	57	0.90	3.5	0.40	1.7	4.0
EMY 63B-4	1/4	0.18	230	1.33	1400	59	0.90	5.0	0.40	1.7	4.5
EMY 71A-4	1/3	0.25	230	1.93	1400	61	0.92	7.0	0.35	1.7	5.5
EMY 71B-4	1/2	0.37	230	2.82	1400	62	0.92	10	0.35	1.7	6.5
EMY 80A-4	3/4	0.55	230	4.07	1400	64	0.92	15	0.35	1.7	9.1
EMY 80B-4	1	0.75	230	5.21	1400	68	0.92	20	0.32	1.7	10.4
EMY 90S-4	1.5	1.1	230	7.13	1400	71	0.95	30	0.32	1.7	13
EMY 90L-4	2	1.5	230	9.4	1400	73	0.95	40	0.30	1.7	16
EMY 100LA-4	3	2.2	230	13.6	1400	76	0.95	65	0.30	1.7	22
EMY 100LB-4	4	3	230	18	1400	77	0.95	88	0.30	1.7	29

## TECHNICAL DATA

### SINGLE PHASE - DUAL CAPACITOR 2 POLE

Motor Type	Rated Output		Voltage (V)	Rated Current In(A)	Rated Speed (r/min)	Efficiency (%)	Full Load Power Factor (cos φ)	Ist (A)	Tst/Tn	Tmax/Tn	Net Weight IM B3 (kg)
	HP	KW									
EML 63A-2	1/4	0.18	230	1.43	2800	60	0.92	7	1.8	1.8	3.9
EML 63B-2	1/3	0.25	230	1.91	2800	63	0.92	10	1.8	1.8	4.3
EML 71A-2	1/2	0.37	230	2.73	2800	67	0.92	16	2.3	1.8	5.8
EML 71B-2	3/4	0.55	230	3.4	2800	73	0.95	21	2.5	1.8	6.8
EML 80A-2	1	0.75	230	4.7	2800	73	0.95	30	2.5	1.8	9.6
EML 80B-2	1.5	1.1	230	7.02	2800	75	0.95	40	2.5	1.8	11.3
EML 90S-2	2	1.5	230	9.44	2800	76	0.95	55	2.5	1.8	13
EML 90L-2	3	2.2	230	13.67	2800	77	0.95	70	2.5	1.8	16
EML 100L-2	4	3	230	18.2	2800	79	0.95	100	2.2	1.8	26
EML 112M-2	5.5	4	230	22.5	2800	78	0.95	120	1.8	1.8	36

### SINGLE PHASE - DUAL CAPACITOR 4 POLE

Motor Type	Rated Output		Voltage (V)	Rated Current In(A)	Rated Speed (r/min)	Efficiency (%)	Full Load Power Factor (cos φ)	Ist (A)	Tst/Tn	Tmax/Tn	Net Weight IM B3 (kg)
	HP	KW									
EML 63A-4	1/6	0.12	230	1.24	1400	55	0.90	6	1.8	1.8	4.1
EML 63B-4	1/4	0.18	230	1.43	1400	56	0.90	8	1.8	1.8	4.9
EML 71A-4	1/3	0.25	230	1.99	1400	62	0.92	12	2.5	1.8	5.8
EML 71B-4	1/2	0.37	230	2.81	1400	65	0.92	16	2.5	1.8	6.8
EML 80A-4	3/4	0.55	230	3.6	1400	69	0.92	21	2.5	1.8	9.1
EML 80B-4	1	0.75	230	5.22	1400	71	0.95	25	2.5	1.8	10.4
EML 90S-4	1.5	1.1	230	6.9	1400	72	0.95	40	2.5	1.8	13
EML 90L-4	2	1.5	230	9.3	1400	74	0.95	50	2.5	1.8	16
EML 100LA-4	3	2.2	230	13.9	1400	76	0.95	80	2.5	1.8	26
EML 100LB-4	4	3	230	17.6	1400	78	0.95	100	2.5	1.8	31
EML 112M-4	5.5	4	230	22	1400	79	0.95	130	2.5	1.8	35

# BRAKE MOTORS

## THREE-PHASE ASYNCHRONOUS MOTORS CAST IRON / ALUMINIUM HOUSING

The Brake Motors Series result from coupling an asynchronous three-phase motor to an electromagnetic DC brake unit.

Due to their reliability and operating safety, as well as their quick braking time (connection and disconnection time = 5 to 80 milliseconds), this series of motors is suitable for a great variety of applications, such as braking loads or torques on the drive shaft, reducing lost time by braking rotating masses, increasing set-up precision through braking operations, and braking operation in accordance with safety rules.

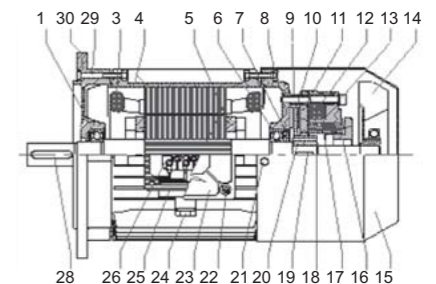
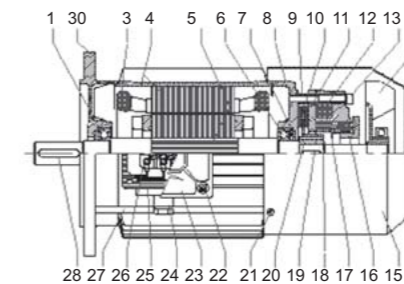
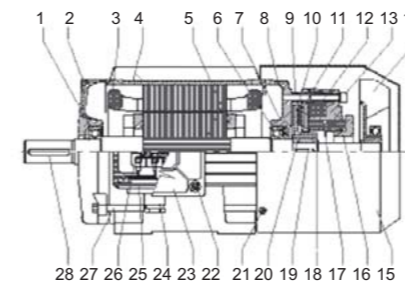
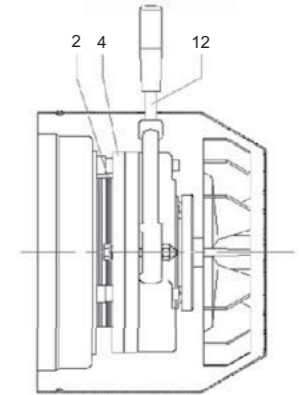
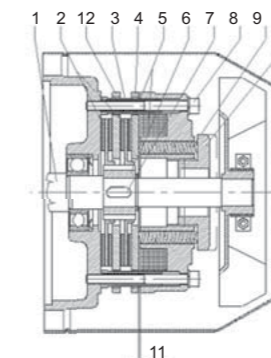
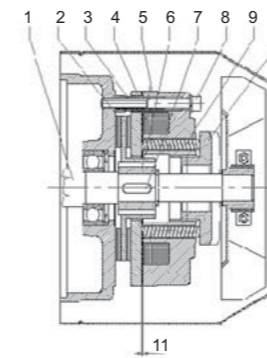

B3 63~160

B5 63~112

B5 132~160

## SPARE PARTS

- FRONT BEARING
- FRONT SHIELD
- WINDING
- FRAME WITH STATOR PACKAGE
- SHAFT WITH ROTOR
- REAR BEARING
- SPRING
- REAR SHIELD
- ADJUSTING BUSH
- BRAKE DISC

- MOVING ANCHOR
- ELECTROMAGNET COIL WITH DIODE
- FIXING SCREWS FOR BRAKE
- COOLING FAN
- FAN HOOD
- RING NUT
- SPRING
- SEE GEARING
- KEY BRAKE SIDE
- TOOTHED PINION

- FIXING SCREW FOR FAN HOOD
- FIXING SCREW FOR TERMINAL-BOX
- TERMINAL-BOX
- ABLE-HOLDER
- PACKING
- TERMINAL-BLOCK
- TIE-BOLT
- COUPLING SIDE KEY
- FIXING SCREW FOR SHIELD
- FLANGE SHIELD

# SLIP RING MOTORS

## THREE-PHASE ASYNCHRONOUS MOTORS CAST IRON HOUSING

The Slip Ring range of three-phase asynchronous motors is ideal for meeting the specific needs of clients who require high torque motors. These motors are exclusively housed in cast iron due to their heavy-duty nature and well-designed exterior, while also conforming to all IEC standards.

Our in-house designed slip ring device, featuring carbon brushes made from high-quality materials and adhering to European motor winding standards and technology, is included with every slip ring motor. These motors are suitable for use in all heavy-duty industries.



## DIMENSIONAL DRAWING

### SLIP RING MOTORS

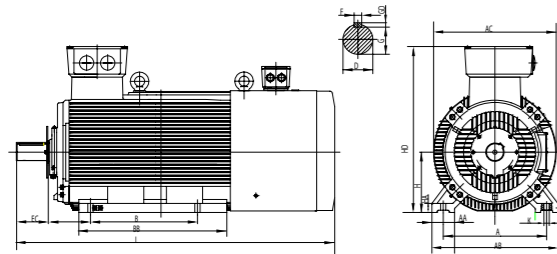

### FOOT MOUNTED B3

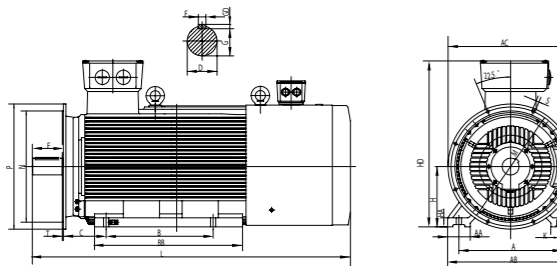

### FOOT & FLANGE MOUNTED B35

Frame Size	A	B	C	D	E	FxGD	G	H	K	M	N	P	S	T	AA	AB	AC	HA	HD	BB	L
200L	318	305	133	55	110	16x10	49	200	19	350	300	400	4xΦ19	5	70	388	420	25	525	375	970
225M	356	311	149	60	140	18x11	53	225	19	400	350	450	8xΦ19	6	75	435	446	28	555	400	1061
250M	406	349	168	65	140	18x11	58	250	24	500	450	550	8xΦ19	6	80	490	495	30	615	450	1150
280S	457	368	190	75	140	20x12	67.5	280	24	500	450	550	8xΦ19	6	85	550	560	35	700	490	1260
280M	457	419	190	75	140	20x12	67.5	280	24	500	450	550	8xΦ19	6	85	550	560	35	700	540	1310
315S	508	406	216	80	170	22x14	71	315	28	600	550	660	8xΦ24	6	125	635	635	45	870	680	1700
315M	508	457	216	80	170	22x14	71	315	28	600	550	660	8xΦ24	6	125	635	635	45	870	680	1700
315L	508	508	216	80	170	22x14	71	315	28	600	550	660	8xΦ24	6	125	635	635	45	870	680	1700
355M	610	560	254	100	210	28x16	90	355	28	740	680	800	8xΦ24	6	125	730	710	52	1010	750	1910
355L	610	630	254	100	210	28x16	90	355	28	740	680	800	8xΦ24	6	125	730	710	52	1010	750	1910
400L	686	710	280	110	210	28x16	100	400	35	975	925	1060	8xΦ24	10	150	840	820	60	1105	985	2115

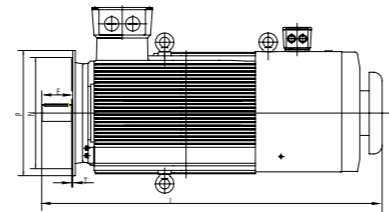

### FLANGE MOUNTED B5 & V1

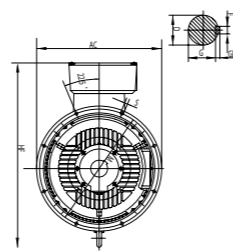

## SLIP RING 4 POLE

Model	Output (k/w)	Speed (r/min)	Rotor Current		Efficiency (%)	PF Cos (φ)	Max. Torque	Rotor Voltage (V)	Rotor Amp (A)	Noise dB(A)	Rotary Inertia (kg.m)	Weight (Kg)
			380V/Δ	415V/Δ								
200L1-4	18.5	1470	33.9	31	89.80%	0.86	3.7	239	47.6	94	0.29	272
200L2-4	22	1470	40	36.6	90.70%	0.86	3.7	281	48	94	0.32	286
225M2-4	30	1475	52.3	47.9	91.70%	0.89	3.3	350	51.5	98	0.63	376
250M1-4	37	1480	67	61.3	91.80%	0.86	3.6	290	79	98	0.87	460
250M2-4	45	1480	80.2	73.4	92.50%	0.87	3.6	338.7	81.7	100	0.98	520
280S-4	55	1472	95	87	92.00%	0.91	3.2	484	71	100	1.86	655
280M-4	75	1477	128	117.2	92.50%	0.91	3.9	277	166	103	2.41	765
315S-4	90	1476	157	143.8	92.80%	0.89	3	296	187	103	3.97	1175
315M-4	110	1481	192	175.8	93.50%	0.88	3.7	328	203	103	4.59	1263
315L1-4	132	1483	230	210.6	94.00%	0.88	4	399	200	106	5.33	1338
315L2-4	160	1484	275	251.8	94.50%	0.89	4	505	191	106	6.11	1450
355M1-4	200	1484	344	315	94.00%	0.89	2.7	627	194	106	10.03	1952
355M2-4	250	1486	438	401	94.50%	0.86	3.5	723	207	108	11.33	2078
355L-4	280	1488	489	447.8	94.80%	0.87	3.5	704	238	108	12.47	2194
400L1-4	315	1485	524	479.8	95.00%	0.91	2.8	557	340	111	17.85	3390
400L2-4	355	1486	587	537.5	95.20%	0.91	2.8	620	344	111	19.34	3515
400L3-4	400	1487	659	603.4	95.50%	0.91	2.8	698	343	111	21.11	3655

## SLIP RING 6 POLE

Model	Output (k/w)	Speed (r/min)	Rotor Current		Efficiency (%)	PF Cos (φ)	Max. Torque	Rotor Voltage (V)	Rotor Amp (A)	Noise dB(A)	Rotary Inertia (kg.m)	Weight (Kg)
			380V/Δ	415V/Δ								
200L2-6	15	980	29.4	26.9	89.20%	0.81	3.1	199.3	48.1	88	0.41	277
22M1-6	18.5	980	35.3	32.3	89.00%	0.83	2.7	187	62.5	88	0.65	335
22M2-6	22	980	41.6	38.1	89.50%	0.83	2.7	224	61	88	0.72	360
250M1-6	30	985	55.3	50.6	91.00%	0.84	3.5	284.7	66.3	91	1.22	480
250M2-6	37	985	68.9	63.1	91.50%	0.84	3.5	338	69	91	1.35	520
280S-6	45	985	81.9	75	92.00%	0.86	3.6	361	77.6	94	2.41	645
280M-6	55	985	98.4	90.1	92.50%	0.86	3.4	486	70.1	94	2.74	695
315S-6	75	987	137	125.4	93.00%	0.85	2.8	266	172	98	5.48	1220
315M-6	90	989	163	149.2	93.50%	0.85	2.8	322	169	98	6.25	1335
315L1-6	110	989	194	177.6	94.00%	0.87	2.8	381	175	98	7.3	1421
315L2-6	132	990	234	214.3	94.20%	0.86	2.8	464	171	98	8.45	1430
355M1-6	160	991	291	266.5	94.50%	0.83	2.8	470	205	102	12.28	1950
355M2-6	200	991	353	323.2	94.80%	0.84	2.7	575	209	102	14.86	2164
355L-6	220	992	388	355.3	94.80%	0.84	2.7	647	204	102	16.71	2273
400L1-6	250	989	444	406.6	94.50%	0.85	2.6	446	337	108	20.69	3345
400L2-6	315	990	553	506.4	94.80%	0.86	2.6	536	352	108	23.73	3545
400L3-6	355	992	627	574.1	95.10%	0.85	2.8	670	315	108	28.28	3835

## SLIP RING 8 POLE

Model	Output (k/w)	Speed (r/min)	Rotor Current		Efficiency (%)	PF Cos (φ)	Torque	Rotor Voltage (V)	Rotor Amp (A)	Noise dB(A)	Rotary Inertia (kg.m)	Weight (Kg)
			380V/Δ	415V/Δ								
200L1-8	11	730	23.7	21.7	87.90%	0.75	2.4	147.3	47.3	82	0.41	276
225M1-8	15	735	31.9	29.2	89.30%	0.75	2.4	169	56	86	0.71	357
225M2-8	18.5	735	39.1	35.8	89.50%	0.75	2.4	211	54	86	0.83	387
250M1-8	22	735	44.5	40.7	90.00%	0.78	3	213.9	64.9	86	1.18	480
250M2-8	30	735	61.5	56.3	90.50%	0.77	3	274	68.4	90	1.4	520
280S-8	37	740	74	67.8	91.30%	0.79	3	281.4	81.7	90	2.36	645
280M-8	45	740	86.3	79	92.30%	0.8	3	357.7	77.7	93	3	735
315S-8	55	742	104	95.2	92.50%	0.79	2.4	486	69	93	5.24	1060
315M-8	75	742	139	127.3	93.30%	0.8	2.4	498	91	96	6.82	1386
315L1-8	90	743	171.8	157.3	93.60%	0.8	2.4	504	108	96	7.82	1475
315L2-8	110	743	209.4	191.7	94.00%	0.8	2.6	514	129	96	9.21	1485
355M1-8	132	743	246	225.3	94.00%	0.81	2.7	462	171	99	13.24	1908
355M2-8	160	744	294	269.2	94.50%	0.82	2.7	562	170	99	16.05	2086
355L-8	185	744	345	315.9	94.50%	0.8	2.8	655	168	99	17.84	2203
400L1-8	200	740	404	369.9	93.80%	0.76	3	464	257	102	18.9	3275
400L2-8	250	740	498	456	94.00%	0.76	3	557	267	105	21.94	3470
400L3-8	315	741	624	571.4	94.50%	0.76	3	696	268	105	26.5	3765

## DIMENSIONAL DRAWING

### NEMA MOTORS

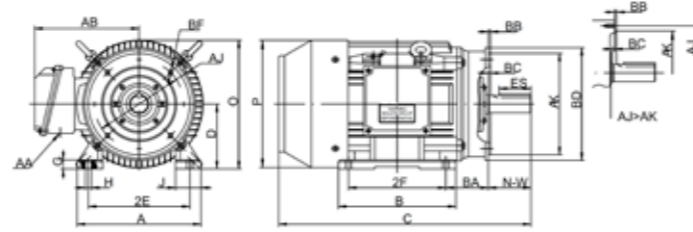

C-FACE FOOT MOUNTED

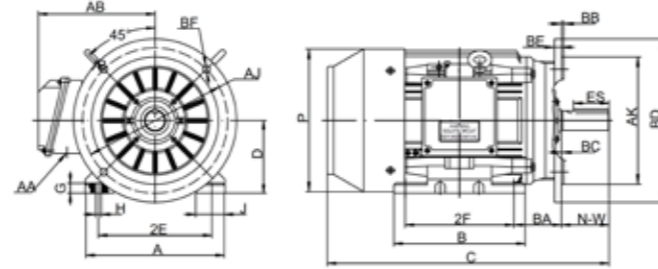

D-FACE FOOT MOUNTED

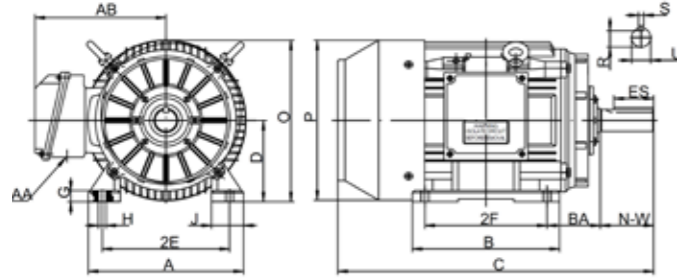

FOOT MOUNTED

Frame	Foot Mounting								Shaft					General						
	A	B	G	J	2E	2F	H	BA	N-W	U	S	R	ES	C	D	O	AA	AB	P	
143T	7	5.12	0.55	1.46	5.5	4	0.34	2.25	2.25	0.875	0.188	0.771	1.41	13	3.5	7.01	3/4	5.9	6.93	
145T		6.1				5								14						
182T	9	6.1	0.675	1.77	7.5	4.5	0.41	2.75	2.75	1.125	0.25	0.986	1.78	15.5	4.5	8.83	3/4	7.17	8.66	
184T		7.09				5.5								16.5						
213T	10.27	7.48	0.71	1.81	8.5	5.5	0.41	3.5	3.38	1.375	0.312	1.201	2.42	18.78	5.25	10.35	1	7.95	10.2	
215T		8.98				7								20.28						
254T	12.36	10.35	0.63	2.36	10	8.25	0.53	4.25	4	1.625	0.375	1.416	2.91	24	6.25	12.44	1-1/4	10.1	12.36	
256T		12.05				10								25.73						
284T	13.8	12.2	0.985	2.95	11	9.5	0.53	4.75	4.62	1.875	0.5	1.591	3.28	27.37	7	13.9	1-1/2	10.83	13.78	
286T		13.7				11								28.87						
284TS	13.8	12.2	0.985	2.95	11	9.5	0.53	4.75	3.25	1.625	0.375	1.416	1.91	26	7	13.9	1-1/2	10.83	13.78	
286TS		13.7				11								27.5						
324T	15.4	13	1.12	3.15	12.5	10.5	0.66	5.25	5.25	2.125	0.5	1.845	3.91	29.8	8	15.9	2	13	15.71	
326T		14.5				12								31.3						
324TS	15.4	13	1.12	3.15	12.5	10.5	0.66	5.25	3.75	1.875	0.5	1.591	2.03	28.3	8	15.9	2	13	15.71	
326TS		14.5				12								29.8						
364T	17.17	14.2	1.24	3.15	14	11.25	0.66	5.88	5.88	2.375	0.625	2.021	4.28	33.47	9	18	3	14.2	18.07	
365T		15.2				12.25								34.47						
364TS	17.17	14.2	1.24	3.15	14	11.25	0.66	5.88	3.75	1.875	0.5	1.591	2.03	31.34	9	18	3	14.2	18.07	
365TS		15.2				12.25								32.34						
404T						12.25														
405T	19.06	17.44	1.33	3.15	16	13.75	0.81	6.62	7.25	2.875	0.75	2.45	5.65	37.76	10	20	3	15.3	19.96	
405TS									4.25	2.125	0.5	1.845	2.78	34.77						
444T	21.93	20.08	1.315	3.94	18	14.5	0.81	7.5	8.5	3.375	0.875	2.88	6.91	44.05	11	22	3	18	22.01	
445T						16.5														
444TS	21.93	20.08	1.315	3.94	18	14.5	0.81	7.5	4.75	2.375	0.625	2.021	3.03	40.3	11	22	3	18	22.01	
445TS						16.5														
447T	21.93	28.6	1.315	3.94	18	20	0.81	7.5	8.5	3.375	0.875	2.88	6.91	52.55	11	22	3	18	22.01	
449T						25														
447TS	21.93	28.6	1.315	3.94	18	20	0.81	7.5	4.75	2.375	0.625	2.021	3.03	48.8	11	22	3	18	22.01	
449TS						25														
447T*	21.93	33.46	1.46	4.1	18	20	0.81	7.5	8.5	3.375	0.875	2.88	6.91	58.65	11	25.37	3	19.7	24.8	
449T*						25														
447TS*	21.93	33.46	1.46	4.1	18	20	0.81	7.5	4.75	2.375	0.625	2.021	3.03	54.91	11	25.37	3	19.7	24.8	
449TS*						25														

Note: The frame size with an asterisk \*, which external dimensions are slightly different from the conventional frame sizes 447/449.

Frame	C-Face						D-F						
	AJ	AK	BB	BC	BD	BF	AJ	AK	BB	BC	BD	BE	BF
143-145T	5.875	4.5	0.16	0.12	6.5	4*3/8-16	10	9	0.25	0	11	0.5	4*0.53
182-184T	7.25	8.5	0.25	0.12	9	4*1/2-13	10	9	0.25	0	11	0.5	4*0.53
213-215T	7.25	8.5	0.25	0.25	8.95	4*1/2-13	10	9	0.25	0	11	0.5	4*0.53
254-256T	7.25	8.5	0.25	0.25	10	4*1/2-13	12.5	11	0.25	0	14	0.75	4*0.81
284-286T/TS	9	10.5	0.25	0.25	11.25	4*1/2-13	12.5	11	0.25	0	14	0.75	4*0.81
324-326T/TS	11	12.5	0.25	0.25	14	4*5/8-11	16	14	0.25	0	18	0.75	4*0.81
364-365T/TS	11	12.5	0.25	0.25	14	8*5/8-11	16	14	0.25	0	18	0.75	4*0.81
404-405T/TS	11	12.5	0.25	0.25	15.5	8*5/8-11	20	18	0.25	0	22	1	8*0.81
444-449T/TS	14	16	0.25	0.25	18	8*5/8-11	20	18	0.25	0	22	1	8*0.81

# NEMA MOTORS

## THREE-PHASE ASYNCHRONOUS MOTORS CAST IRON / ALUMINIUM HOUSING

NEMA EPACT and Premium Efficiency 3-Phase Motors are available in cast iron TEFC and ODP styles, ranging from 1HP to 250HP and in frame sizes 143T through 449T. Customers can choose from a service factor of 1.15 or 1.25, and NEMA Design B or C options.

These motors are commonly used in applications such as pumps, compressors, and fan industries, as well as in energy-saving applications, conveyor systems, gear reducers, and applications that require Design C torque.



## MODEL DATA

### FEATURES

- 208-230/460V/60HZ OR 575V/60HZ
- NEMA SERVICE FACTOR 1.15/1.25
- CONTINUOUS DUTY 40°C AMBIENT
- TEFC (TOTALLY ENCLOSED FAN COOLED)
- CLASS F INSULATION WITH CLASS B TEMP RISE
- CAST IRON FRAMES
- NEMA DESIGN B OR C
- BALL BEARINGS
- IP55 PROTECTION
- UP TO 455T AVAILABLE WITH INTEGRAL OR REMOVABLE FEET

### APPLICATIONS

- PUMPS
- COMPRESSORS
- FANS
- MACHINE TOOLS
- ENERGY SAVING APPLICATIONS
- OTHER GENERAL PURPOSE THREE PHASE APPLICATIONS

### APPLICATIONS (DESIGN C)

- CONVEYORS
- GEAR REDUCERS
- APPLICATIONS REQUIRING DESIGN C TORQUE

TXC Series NEMA Premium Efficiency TEFC Motors Design A

HP	Full Load Speed (r/min)	NEMA Frame	Full Load Current			Eff. 100% FL	Power Factor (cosφ)	Full Load Torque (lb-ft)	KVA Code	Locked Rotor		BDT (%FL)	Service Factor	Moment of Inertia (lb-in <sup>2</sup> )	Net weight (lbs)
			1230V (A)	1460V (A)	1575V (A)					LRA 230V (A)	LRT (%FL)				
1	3500	143T	3	1.5	1.2	77	0.83	1.5	K	22	220	300	1.25	0.0278	41.2
	1740	143T	3	1.5	1.2	85.5	0.75	3.02	J	19	280	300	1.25	0.0657	46.3
	1150	145T	3.4	1.7	1.3	82.5	0.68	4.57	H	17	200	270	1.25	0.1153	52.9
1.5	3500	143T	4	2	1.6	84	0.84	2.25	K	32	220	300	1.25	0.0373	41.9
	1740	145T	4.4	2.2	1.7	86.5	0.75	4.53	L	34	280	300	1.25	0.0885	54
	1175	182T	4.8	2.4	1.9	87.5	0.66	6.71	L	35	220	300	1.25	0.4286	93.7
2	3500	145T	5.2	2.6	2.1	85.5	0.85	3	L	47	220	300	1.25	0.047	48.5
	1740	145T	5.6	2.8	2.2	86.5	0.78	6.04	K	42	280	300	1.25	0.1113	59.5
	1175	184T	6.2	3.1	2.5	88.5	0.68	8.94	L	46	220	300	1.25	0.57	112.5
3	3510	182T	7.2	3.6	2.9	86.5	0.9	4.49	K	61	200	280	1.25	0.1115	82.7
	1750	182T	8	4	3.2	89.5	0.79	9.01	L	71	220	300	1.25	0.2831	94.8
	1175	213T	8.8	4.4	3.5	89.5	0.72	13.41	K	67	200	300	1.25	1.0268	147.7
5	3510	184T	11.4	5.7	4.6	88.5	0.92	7.48	K	107	200	280	1.25	0.1607	97
	1750	184T	12.6	6.3	5	89.5	0.83	15.01	K	108	220	300	1.25	0.3669	110.3
	1175	215T	13.8	6.9	5.5	89.5	0.76	22.36	K	105	200	300	1.25	1.2912	172
7.5	3520	213T	17.4	8.7	7	89.5	0.9	11.19	J	150	200	280	1.25	0.3479	140
	1750	213T	17.8	8.9	7.1	91.7	0.86	22.52	J	142	200	250	1.25	0.9082	159
	1170	254T	20.8	10.4	8.3	91	0.74	33.68	K	167	200	250	1.25	2.07	247
10	3520	215T	22.6	11.3	9	90.2	0.92	14.93	K	214	200	280	1.25	0.4533	165
	1750	215T	23.8	11.9	9.5	91.7	0.86	30.02	J	189	200	250	1.25	1.1149	182
	1175	256T	27.8	13.9	11.1	91	0.74	44.72	K	222	200	250	1.25	2.6008	278
15	3550	254T	33.6	16.8	13.4	91	0.92	22.2	K	303	200	280	1.25	1.2283	255
	1770	254T	35.4	17.7	14.1	92.4	0.86	44.53	J	285	220	300	1.25	2.2164	279
	1180	284T	37.8	18.9	15.1	91.7	0.81	66.79	L	340	200	280	1.25	5.7264	364
20	3550	256T	45.2	22.6	18.1	91	0.91	29.6	J	379	200	280	1.25	1.3261	276
	1770	256T	46.8	23.4	18.7	93	0.88	59.37	K	424	200	300	1.25	2.7824	331
	1180	286T	49.8	24.9	19.9	91.7	0.82	89.05	K	442	200	280	1.25	6.6386	404
25	3545	284TS	56.8	28.4	22.7	91.7	0.9	37.05	H	415	200	250	1.25	1.8016	354
	1775	284T	58.2	29.1	23.3	93.6	0.86	74	K	545	220	300	1.25	3.5714	366
	1180	324T	62.2	31.1	24.9	93	0.81	111.32	K	559	200	280	1.25	9.3474	501
30	3550	286TS	68	34	27.2	91.7	0.9	44.4	J	598	200	250	1.25	1.9359	375
	1775	286T	69.8	34.9	27.9	93.6	0.86	88.8	K	662	220	300	1.25	4.0399	397
	1180	326T	74.6	37.3	29.8	93	0.81	133.58	K	671	200	280	1.25	10.6666	648
40	3555	324TS	91	45.5	36.4	92.4	0.89	59.12	H	689	200	280	1.25	3.3692	485
	1780	324T	93.6	46.8	37.5	94.1	0.85	118.07	H	680	200	220	1.25	7.1424	539
	1185	364T	92.6	46.3	37	94.1	0.86	177.36	K	818	220	280	1.15	15.8991	725
50	3560	326TS	111.8	55.9	44.7	93	0.9	73.79	J	939	200	280	1.25	4.0145	529
	1780	326T	115.2	57.6	46.1	94.5	0.86	147.59	J	998	200	220	1.25	8.3396	601
	1185	365T	116	58	46.3	94.1	0.86	221.69	K	1099	220	280	1.15	18.2263	792
60	3560	364TS	134	67	53	93.6	0.9	88.55	K	1252	200	280	1.15	7.2912	762
	1780	364T	136	68	54	95	0.87	177.11	K	1338	220	280	1.15	16.1862	783
	1185	404T	140	70	56	94.5	0.85	266.03	J	1104	200	230	1.15	28.8796	976
75	3560	365TS	165	82	66	93.6	0.91	110.69	G	1184	200	280	1.15	8.5	785
	1780	365T	167.2	83.6	67	95.4	0.88	221.38	K	1675	220	280	1.15	18.9957	873
	1185	405T	173	87	69	94.5	0.86	332.54	H	1303	200	230	1.15	34.1302	1045
100	3565	405TS	222	111	88	94.1	0.9	147.38	K	2080	220	280	1.15	11.8424	1021
	1780	405T	228	114	91	95.4	0.86	295.18	L	2266	220	280	1.15	20.8694	1025
	1190	444T	230	115	92	95	0.86	441.53	H	1721	200	250	1.15	76.1733	1590
125	3570	444TS	-	134	107	95	0.92	183.97	K	2512	200	250	1.15	22.397	1438
	1785	444T	-	138	110	95.4	0.89	367.94	K	2536	250	320	1.15	45.1563	1480
	1190	445	-	147	117	95	0.84	551.91	J	2317	200	250	1.15	84.8372	1731
150	3570	445TS	-	159	127	95	0.93	220.76	H	2652	200	250	1.15	25.9333	1544
	1785	445T	-	165	132	95.8	0.89	441.53	K	3258	250	320	1.15	55.5355	1632
	1190	447T	-	175	140	95.8	0.84	662.29	K	3072	200	250	1.15	102.6656	2042
200	3570	447TS	-	218	171	95.4	0.9	294.35	K	3840	200	250	1.15	30.7095	1859
	1785	447T	-	217	174	96.2	0.9	588.7	H	3411	250	250	1.15	71.6045	2055
	1190	449T	-	233	186	95.8	0.84	883.05	K	4091	200	250	1.15	123.7071	2245
250	3570	449TS	-	271	212	95.8	0.9	367.94	K	4781	200	250	1.15	36.8791	2024
	1785	449T	-	270	216	96.2	0.9	735.88	H	4374	250	250	1.15	85.4436	2289
	1190	449T*	-	291	233	95.8	0.84	1103.82	J	4654	200	250	1.15	150.937	2597
300	3570	449TS	-	326	261	95.8	0.9	441.53	H	5212	200	250	1.15	63.641	2271
	1785	449T	-	324	260	96.2	0.9	883.05	H	5191	250	250	1.15	97.532	2443
	1190	449T*	-	349	279	95.8	0.84	1324.58	J	5585	200	250	1.15	171.998	3025
350	3570	449TS*	-	384	307	95.8	0.89	515.11	H	6150	200	250	1.15	53.676	2602
	1785	449T*	-	387	310	96.2	0.88	1030.23	H	6194	250	250	1.15	118.256	2849
	1190	449T*	-	407	326	95.8	0.84	1545.34	J	6516	200	250	1.15	190.792	3237
400	3570	449TS*	-	439	351	95.8	0.89	588.7	H	7028	200	250	1.15	63.597	2884
	1785	449T*	-	442	354	96.2	0.88	1177.41	H	7078	250	250	1.15	130.047	3025
	1190	449T*	-	465	372	95.8	0.84	1766.11	J	7446	200	250	1.15	219.023	3554
450	3570	449TS*	-	494	395	95.8	0.89	662.29	H	7907	200	250	1.15	68.581	3025
	1785	449T*	-	498	398	96.2	0.88	1324.58	H	7963	250	250	1.15	146.554	3272
500	3570	449TS*	-	549	439	95.8	0.89	735.88	H	8785	200	250	1.15	78.5	3308
	1785	449T*	-	553	442	96.2	0.88	1471.76	H	8848	250	250	1.15	163.051	3519

\*The frame size and external dimensions with an asterisk (\*), should be one-to-one correspondence relationship

NEMA EPACT Efficiency TEFC Motors Design C

HP	Full Load Speed (r/min)	NEMA Frame	Conn	Code	Current at 460 V		Torque			Efficiency Full Load (%)
					Full Load (A)	Locked Rotor (A)	Full Load LB-FT	Locked Rotor (%)	Break Down (%)	
1	3450	143T	2Y/Y	N	1.4	15	1.5	245	225	74
	1720	143T	2Y/Y	N	1.7	15	3.1	285	200	73
	1150	145T	2Y/Y	N	2	15	4.6	255	225	72
1.5	3450	143T	2Y/Y	M	2.1	20	2.2	240	225	78
	1720	145T	2Y/Y	M	2.4	20	4.5	285	200	77
	1150	182T	2Y/Y	M	2.6	20	6.8	250	225	72
2	3450	145T	2Y/Y	L	2.8	25	3	240	225	79
	1720	145T	2Y/Y	L	3.1	25	6.1	285	200	78.5
	1150	184T	2Y/Y	L	3.3	25	9.2	250	225	78.5
3	3450	182T	2Y/Y	K	4	32	4.5	240	225	80
	1720	182T	2Y/Y	K	4.3	32	9	270	200	82.5
	1150	213T	2Y/Y	K	4.7	32	13.5	250	225	81.5
5	3450	184T	2Y/Y	J	6.4	46	7.5	240	200	82
	1720	184T	2Y/Y	J	6.9	46	15.2	255	200	82.5
	1150	215T	2Y/Y	J	8.3	46	22.6	250	200	82.5
7.5	3450	213T	2Y/Y	H	9.4	64	11.2	215	200	83
	1720	213T	2Y/Y	H	9.9	64	22.5	250	200	84
	1150	254T	2Y/Y	H	11.2	64	33.8	225	190	86.5
10	3450	215T	2Y/Y	H	12.2	81	15	215	190	84
	1720	215T	2Y/Y	H	13	81	30.5	250	200	84
	1150	256T	2Y/Y	H	15	81	45	225	190	86.5

# HIGH VOLTAGE MOTORS

THREE-PHASE ASYNCHRONOUS MOTORS  
CAST IRON HOUSING

Industries that require the movement of heavy loads or complex applications often use high voltage motors. These motors are a part of our extensive range of reliable and efficient industrial motors, suitable for use in cement plants, pump systems, mines, chemical, oil and gas industries, plant manufacturers and other users worldwide.

Elektrim Motors produces medium to high voltage asynchronous motors with nominal voltages ranging from 3,000V to 10,000V. We offer various electrical and mechanical designs, as well as different types of protection and cooling options. Our motors are designed for both mains and inverter operation and comply with the current standards EN60034, IEC60034, and ISO.

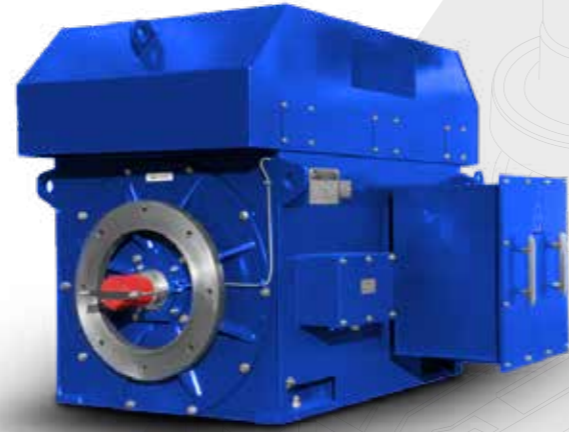

## MODEL DATA

### PRODUCT SPECIFICATIONS / DETAILS

**FRAME SIZE:** EM355 – EM710

**POLE:** 2P, 4P, 6P, 8P, 10P, 12P, 14P 16P

**EFFICIENCY:** IE1-IE3

**VOLTAGE:** 3,000V - 10,000V

**FREQUENCY:** 5Hz - 100Hz

**PROTECTION:** IP55, IP65, IP56

**INSULATION:** CLASS F / CLASS H

**RUNNING DUTY:** S1 CONTINUOUS RUNNING

**COOLING METHOD:** AIR COOL(IC611, IC616, IC666) AND WATER COOLED (IC81W)

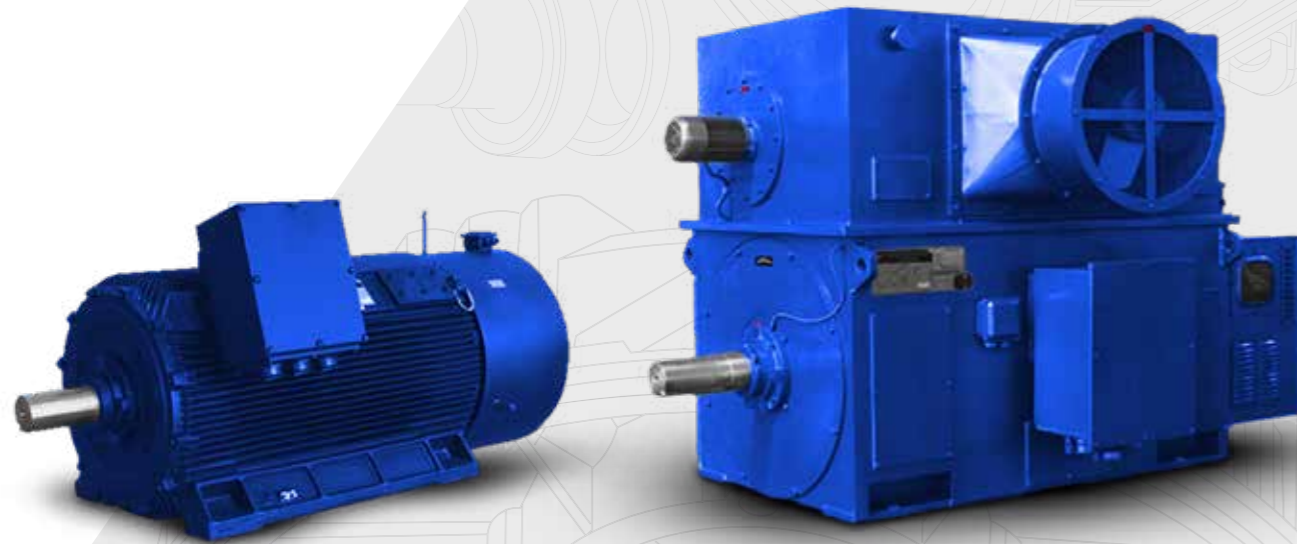

# FIRE PUMP MOTORS

THREE-PHASE ASYNCHRONOUS MOTORS  
CAST IRON HOUSING

UL certified Fire Pump motors are specifically designed to be used on fire pumps that adhere to NFPA-20 standards. These motors have a Service factor of either 1 or 1.15, and are available in IE1 to IE3 ratings.

They are ideal for any purpose-driven pump utilized within a fire protection system.

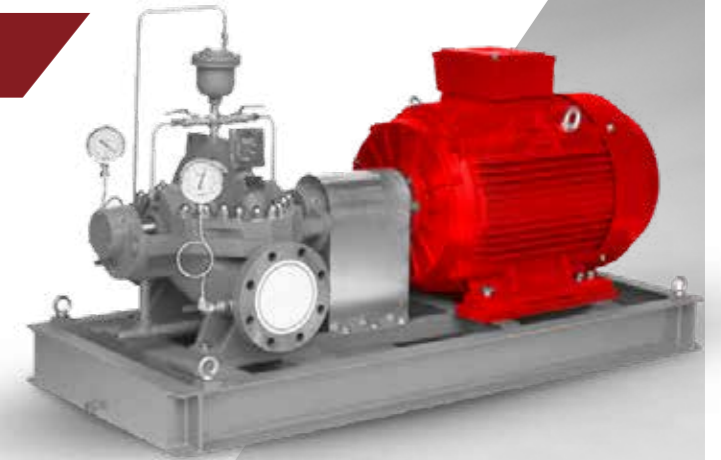

## CERTIFICATION

### UL LISTED CERTIFICATE



# EXPLOSION PROOF MOTORS

THREE-PHASE ASYNCHRONOUS MOTORS  
CAST IRON HOUSING

The Explosion-proof Motor Series is manufactured according to international IEC standards and conforms to the international ATEX certificate for all frame sizes and many different ex-proof requirements.

This series of motors is designed to conform to the standards of Exd IIA T4, Exd IIB T4, and Exd IIC T4.

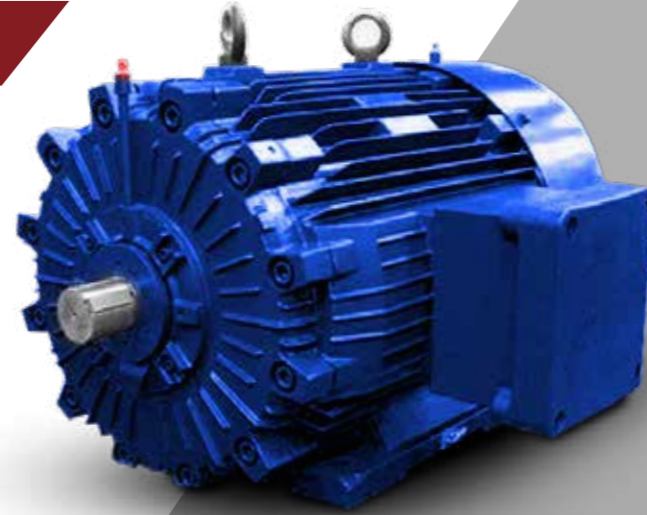

## CERTIFICATION

ATEX CERTIFICATE



# GL-DNV MARINE MOTORS

THREE-PHASE ASYNCHRONOUS MOTORS  
CAST IRON HOUSING

The Elektrim Techtop Motors designed for marine use conform to the International IEC standards and can be supplied with a GL Type Approval Certificate for all frame sizes.

They are also suitable for third-party certification testing by major marine certification societies. These motors are widely used in different industrial and marine sectors globally and are a dependable prime mover for all kinds of marine applications.

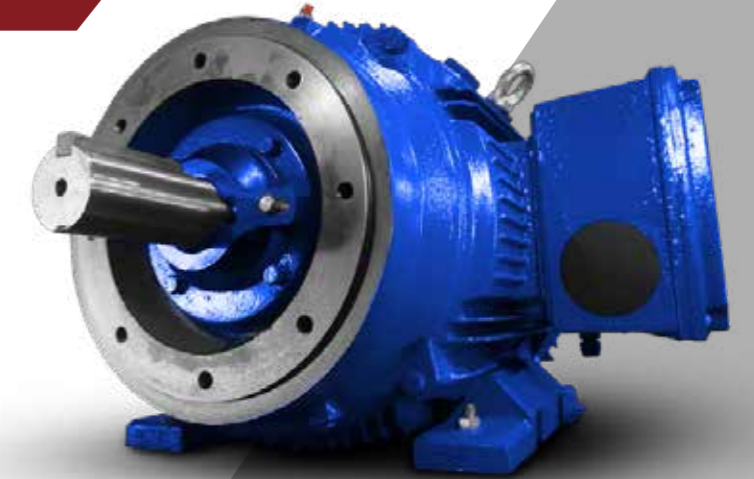

## CERTIFICATION

DNV-GL MARINE CERTIFICATE

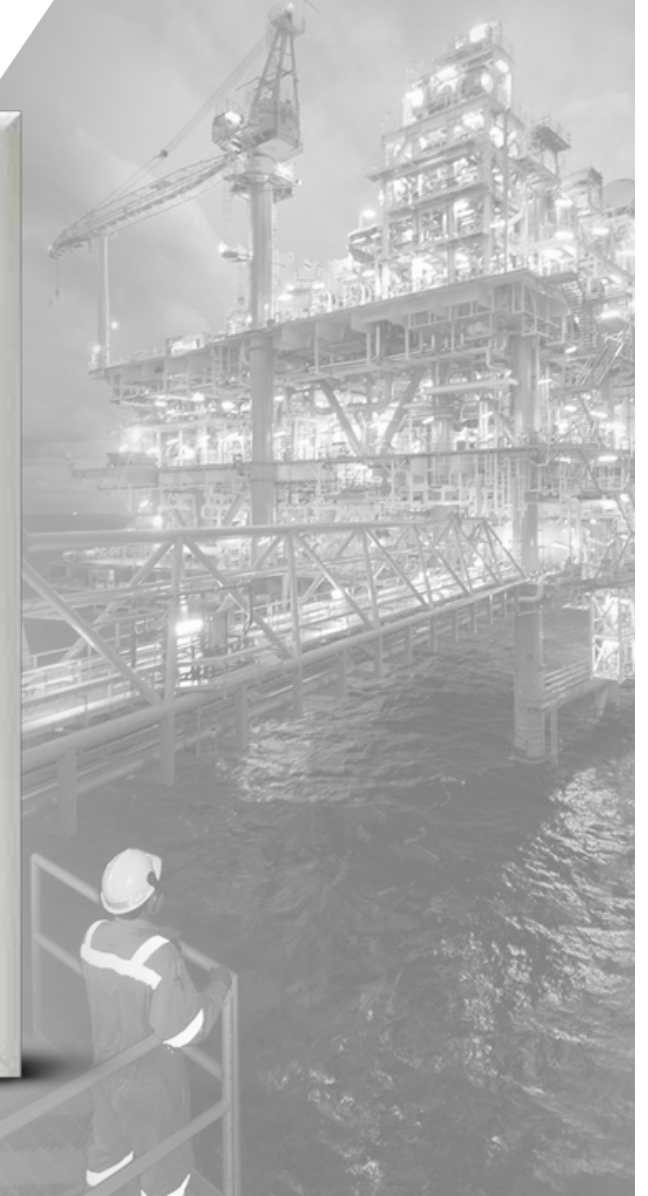

# **Elektrim** TECHTOP

PRODUCT CATALOGUE

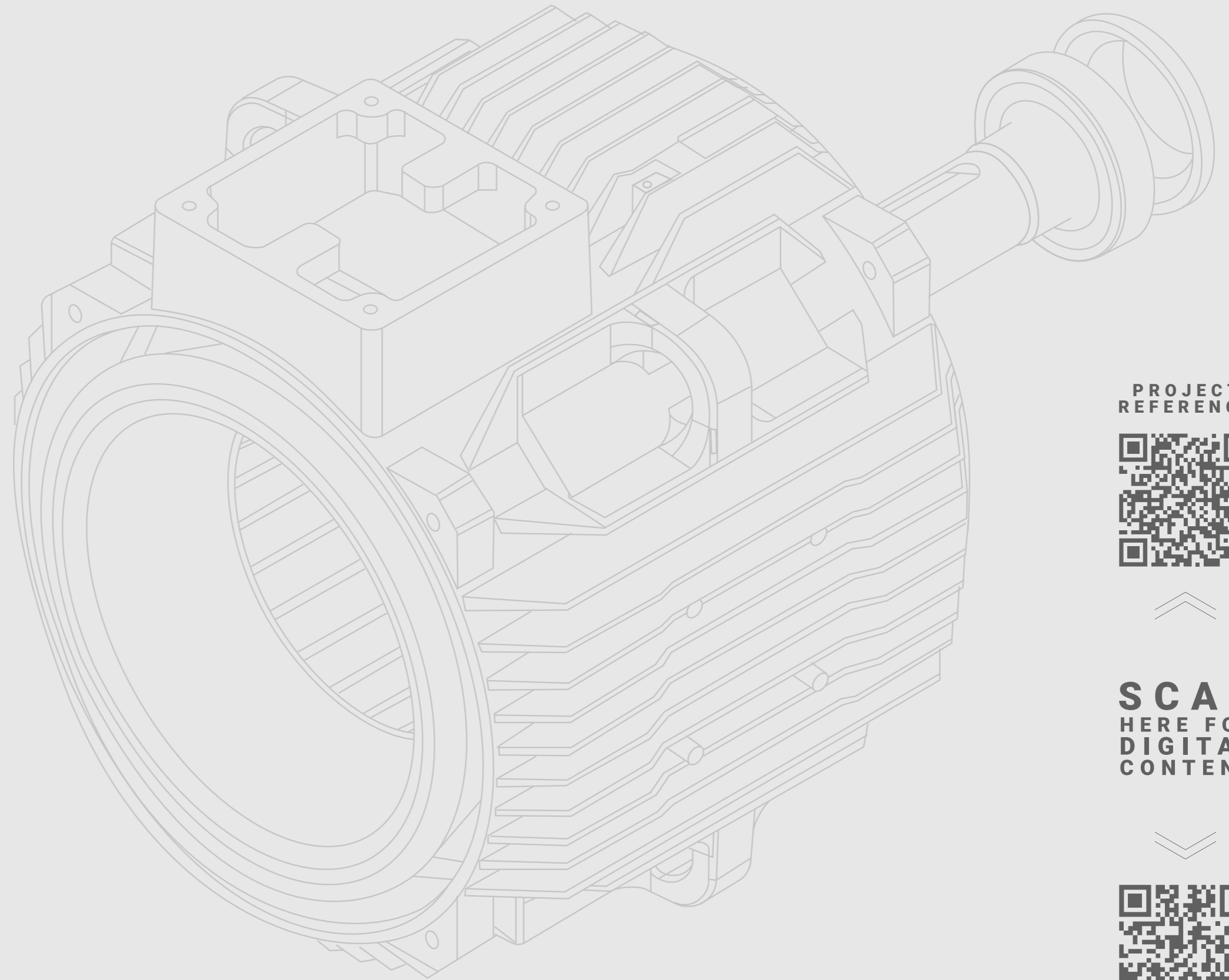

PROJECT  
REFERENCE

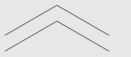
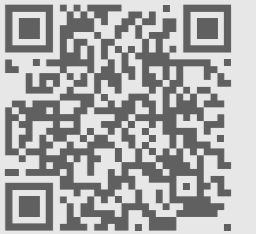

**SCAN**  
HERE FOR  
DIGITAL  
CONTENT



WEBSITE



***Elektrim***  
TECHTOP



**SCAN**  
HERE FOR  
FOR DIGITAL COPY